

BIOMARINE

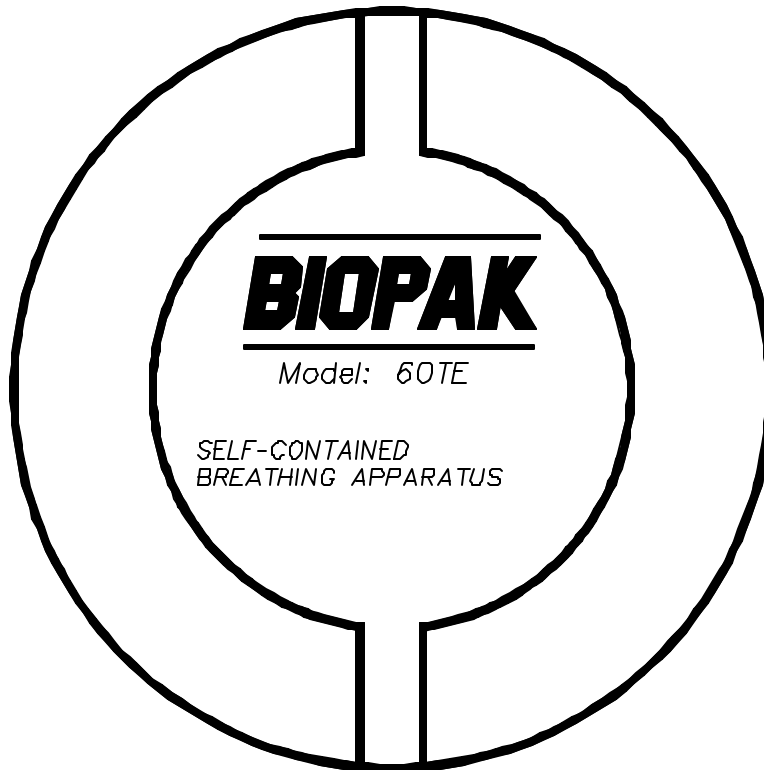

Benchman Manual

Biomarine Incorporated

456 Creamery Way
Exton, PA 19341 USA

Phone: (610) 524-8800
Fax: (610) 524-8807
Email: NeutronicsInc.com

Table of Contents

Subject	Page
NIOSH Approval Label	4
I. Cautions and Limitations	5
II. S. Special or Critical User's Instructions	5
III. Theory of Biopak Operation	7
A. Biopak Description	7
B. Breathing Loop	9
C. High Pressure Plumbing	10
D. Low Pressure Plumbing	11
IV. Turn-Around Maintenance Procedure	12
A. Turn-Around Maintenance Tag	12
B. Biopak Disassembly	12
C. Washing and Disinfecting	13
D. Oxygen Cylinder Charging	14
E. Biopak Re-Assembly	15
F. Flow Test	16
G. Carbon Dioxide Absorbent Charging and Installation	16
H. Facepiece Concerns	17
I. Final Re-Assembly	18
V. Periodic Long-Term Maintenance	19
A. Visual Inspection	19
B. High Pressure Leak Testing	19
C. Low Pressure Leak Testing	20
D. Flow Testing	20
E. Optional Facepiece Fit Testing	21
VI. General Service Procedures	22
A. Scheduled Component Replacement	22
B. System Lubrication	23
C. Oxygen Cylinder	24
D. Regulator Assembly	24
E. Bypass Valve Assembly	25
F. Alarm Whistle Assembly	26
G. Flow Restrictor Assembly	27
H. Breathing Chamber Assembly	27
I. Harness and Straps	31
J. Facepiece Assembly	32
K. Factory Service and Training	35
VII. Troubleshooting Guide	36
VIII. Biopak Specifications	40
IX. Warranty Statement	41

X. Illustrated Parts Lists	43
A. Top Assembly	43
B. Lower Housing Assembly	45
C. Upper Housing Assembly	46
D. Pneumatic Assembly	47
E. Bypass Valve Assembly	48
F. Breathing Chamber Assembly	49
G. Diaphragm Assembly	51
H. Carbon Dioxide Scrubber Assembly	52
I. Breathing Hose Assemblies	53
J. Breathing Chamber Cover Assembly	54
K. Oxygen Cylinder Assembly	55
L. Scott-Style Facepiece Assembly	56
M. Scott-Style Facepiece Wiper Assembly	57
N. AGA-Style Facepiece Assembly	58
O. AGA-Style Facepiece Wiper Assembly	60
P. Service Kit Assembly	61
Appendix A: Maintenance Log Sheet	62
Appendix B: Material Hazards, Handling and First Aid	63

I. Cautions and Limitations

- ◆ Failure to properly use and maintain this product could result in injury or death.
- ◆ All approved respirators shall be selected, fitted, used and maintained in accordance with MSHA, OSHA and other applicable regulations.
- ◆ Never substitute, modify, add or omit parts. Use only exact replacement parts in the configuration as specified by the manufacturer.
- ◆ Refer to User's Instructions and/or maintenance manuals for information on use and maintenance of these respirators.
- ◆ Special or critical User's Instructions and/or specific use limitations apply. Refer to User's Instructions before donning.

II. S. Special or Critical User's Instructions

- ◆ All users of the Self-Contained Breathing Apparatus (SCBA) must be trained by qualified instructors in donning, operation, inspection and emergency use procedures.
- ◆ All repairs beyond the scope of this manual must be performed by Biomarine Incorporated or a qualified Biomarine Service Center.
- ◆ Prior to using the SCBA it must be determined that user is medically fit. The following are some, but not all, medical and psychological conditions that could limit the use of the SCBA:
 - Emphysema
 - Chronic Obstructive Pulmonary Disease
 - Bronchial Asthma
 - X-ray evidence of Pneumonia
 - Evidence of reduce pulmonary function
 - Coronary Artery Disease
 - Severe or progressive hypertension
 - Epilepsy-Grand Mal or Petit Mal
 - Pernicious Anemia
 - Diabetes-Insidious or Mellitus
 - Breathing difficulties when wearing a SCBA
 - Claustrophobia or anxiety when wearing a SCBA
 - Abnormal or ruptured ear drum
- ◆ **Compressed Oxygen Hazard:** Always handle oxygen cylinders with care to prevent rupture. Do not allow oil, grease or other combustible materials to come in contact with the cylinder or cylinder valve to prevent ignition. Do not open the cylinder valve in the presence of open flame or sparks to prevent ignition. Failure to heed this warning may result in personal injury or death due to sudden release of high-pressure oxygen and/or fire.
- ◆ **Oxidizing Agent Hazard:** Oxygen is a non-flammable gas; however, it will enhance the combustion of other materials. Oxygen enrichment will decrease the energy required for the ignition of materials. In an oxygen rich environment, oxygen concentration exceeding 23% by volume at sea level, materials that normally will not burn in air may burn; and, materials that do burn in air will burn more vigorously and at a higher temperature. Oxygen will not cause materials to ignite unless there is an ignition source present.

- ◆ This SCBA is approved for respiratory protection during entry into and escape from oxygen deficient atmospheric gases and vapors at temperatures above -15°F.
- ◆ This SCBA is approved only when the oxygen cylinder is fully charged with compressed oxygen meeting U.S.P. specifications.
- ◆ The oxygen cylinder shall meet applicable DOT specifications and shall be marked "COMPRESSED BREATHING OXYGEN".
- ◆ Do not use this apparatus near open flames or in high radiant heat.
- ◆ After each use of this apparatus, a fully charged breathing gas container and a recharge of carbon dioxide absorbent shall be installed.
- ◆ Thorough cleaning and disinfecting of the facepiece, breathing tube and breathing bag must be done in accordance with the manufacturer's instructions.
- ◆ Use with adequate skin protection when worn in gases or vapors that poison by skin absorption (for example hydrocyanic acid gas).
- ◆ A good facepiece seal is important since facepiece leakage will severely reduce service time.
- ◆ Use of pure oxygen or enriched air increases the flammability and lowers the ignition temperature of most materials.
- ◆ Special handling procedures shall be instituted when utilizing the carbon dioxide scrubber material, Soda-Sorb, and the anti-fog facepiece solution. Refer to Appendix B of this manual for details.
- ◆ NIOSH limitation "*I-Contains electrical parts which have not been evaluated as an ignition source in flammable or explosive atmospheres by MSHA/NIOSH*" applies to use of facepiece with voice projection module (400-471 G12) only.

III. Theory of Biopak Operation

A. Biopak Description

The Biopak 60TE is a sixty-minute, self-contained, closed-circuit, positive-pressure breathing apparatus that is NIOSH approved for entry into and escape from oxygen deficient atmospheres. The apparatus differs from open-circuit devices in that all breathing air is recycled and confined within the device itself. Only during periods of high volumetric exhalation will any breathing atmosphere be vented into the surround ambient atmosphere. Breathing air is continually recycled in the device with exhaled carbon dioxide from the user captured by means of an absorbent media. Breathing gas volumes lost through the absorption of carbon dioxide are directly replaced with a constant bleed of 100% oxygen from an on-board supply. Breathing gas is continually cooled through the use of phase-changing salts to maintain user comfort throughout the sixty-minute duration of the apparatus.

The apparatus is supplied with a full facepiece and is housed in a clamshell type backpack housing. Hoses extend through the top of the housing to connect on either side of the facepiece to provide full mobility and viewing angles to the user.

The Biopak consists a three main sub-systems, the Breathing Loop, The High Pressure Plumbing and the Low Pressure Plumbing. The Breathing Loop consists of all components that are in direct contact with the breathing atmosphere to the user. High Pressure Plumbing components work to reduce the high pressure of the on-board oxygen supply to acceptable levels for use in breathing. Low Pressure Plumbing components deliver the reduced pressure oxygen into the Breathing Loop. Figure 1 provides a graphical representation of the complete respirator system.

Alarm features are provided to warn the user when oxygen stores are either running out or have not been activated. A chest-mounted pressure gauge will provide the user with a visual real-time indication of remaining oxygen stores and will provide a visual alarm when only fifteen-minutes of oxygen supply remains. An alarm whistle will provide a 92dB sounding when remaining oxygen stores will provide fifteen-minutes of operation. An anti-anoxia feature will prevent use of the respirator whenever oxygen stores have not been installed or activated by the user.

A counter-lung and spring arrangement is utilized to maintain positive pressure in the device during the exhalation and inhalation cycles of the respiration. The positive pressure will insure that the entire breathing loop of the respirator is greater than the external ambient pressure. This will insure that leakage, such as around the facepiece seal, is out of rather than into the respirator. Outward leakage will lessen the potential for the migration of harmful external agents into the breathing atmosphere. The Biopak 60TE has a *Protection Factor* greater than 20,000 that has been derived from a *Quantitative Fit Test*. In the *Quantitative Fit Test* the rebreather is exposed to an ambient atmosphere heavily laden with particle contamination. A measure of the particle concentration outside of the respirator is divided by a measure of the particle concentration in the respirator facepiece to establish the *Protection Factor*.

The Biopak has been utilized in mine rescue, tunneling, hazardous material remediation, fire fighting, chemical and biological warfare and numerous other applications. Anywhere a potential exists for an oxygen deficient atmosphere or an atmosphere that may contain a human health hazard agent can be considered an application of the Biopak.

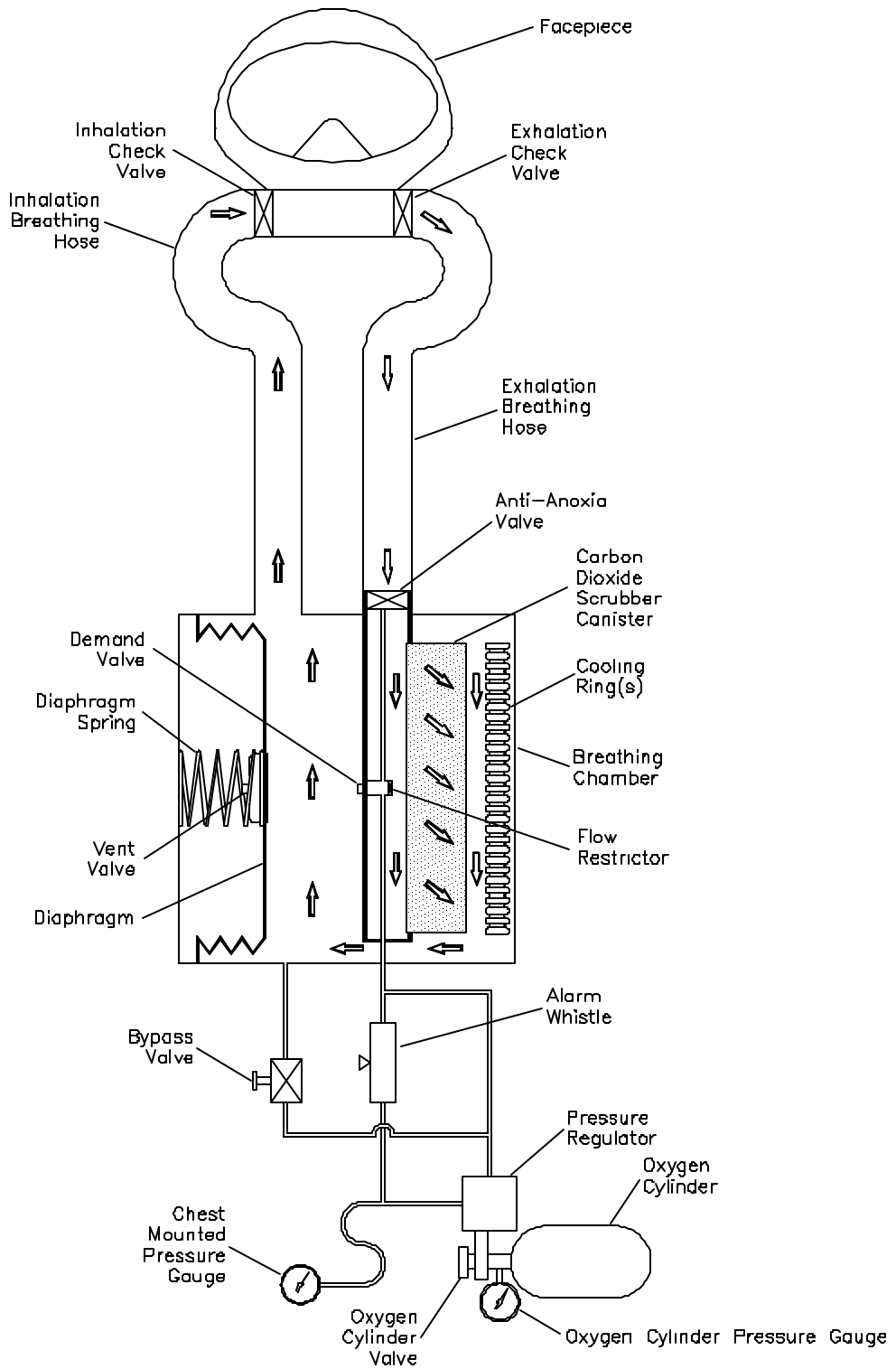

Figure 1: Biopak 60TE Flow Diagram

B. Breathing Loop

The breathing loop consists of all components that are direct contact with the breathing atmosphere. Referring to Figure 1, the breathing loop includes the facepiece, the exhalation hose, the breathing chamber, the coolant rings and the inhalation hose. These components all work to provide a positive pressure breathing atmosphere of 90-100% by volume oxygen and 90-100% relative humidity.

Facepiece: The facepiece will fit directly onto the face of the user and will provide coverage from under the chin to the forehead. Check valves are provided in the facepiece to force breathing atmosphere flow in the preferred direction. The check valves will also insure that the breathing atmosphere does not hang-up or remain in the facepiece, which could result carbon dioxide build-up and poisoning. The facepiece is available in multiple sizes and styles (Scott and AGA) to provide the best fit to the user. Facepiece fit is critical in maintaining the positive pressure seal and conserving the duration of the respirator. Standard facepieces are supplied with speaking diaphragms, an anti-fog lens insert and nose cup. Optional features include lens wipers, spectacle mounting kits, voice amplification kits and voice communication systems.

Exhalation Breathing Hose: The exhalation breathing hose is a flexible hose that will transfer user exhalation from the mask and into the breathing chamber.

Breathing Chamber: The breathing chamber provides carbon dioxide absorption, maintains system positive pressure, maintains system volumetric control through venting and adding, provides breathing gas cooling and provides anti-anoxia protection. The specific components of the breathing chamber are as follows:

Anti-Anoxia Valve: The anti-anoxia valve is simply a plug that will restrict the exhalation hose connection to the breathing chamber in the event oxygen stores have not been installed or activated in the respirator. Once the oxygen stores have been activated, a pneumatic cylinder will withdraw the plug from the exhalation hose port. When the plug is in the exhalation hose port the resulting breathing resistance will make it impossible for the user to breathe the respirator thus providing a direct indication of no oxygen pressure.

Diaphragm and Diaphragm Spring: The diaphragm and spring combine to form the counter-lung. The counter-lung will react in an opposite direction from the user lungs thus maintaining positive pressure.

Vent Valve: The vent valve is located on the diaphragm and is mechanically actuated whenever the exhalation of the user exceeds the tidal volume of the respirator. Once the respirator tidal volume has been exceeded, the vent valve will be forced open to release excess gas. This will insure that exhalation breathing resistances do not build up and cause user discomfort. The valve is a two-stage device providing dual seals for added protection.

Demand Valve: The demand valve is a mechanically actuated valve located at the upper end of the diaphragm inhalation travel stroke. In periods of heavy loads the user requirements may exceed those of the standard respirator function. The demand valve will open to admit additional flow of oxygen into the breathing loop. This device insures that the respirator will supply the user with additional oxygen as required and will also insure against the respirator going into a negative pressure situation during inhalation.

Cooling Rings: Two sealed rings containing sodium phosphate crystals are positioned within the stainless steel cover of the breathing chamber. Hot recycled breathing gas will contact the cooling rings causing the crystals to melt and absorb excessive heat. The phase change of the crystals will maintain the breathing gas temperature below NIOSH requirements. The crystals are self-regenerating and require no user intervention for re-use.

Breathing Chamber (continued)

Flow Restrictor: The flow restrictor admits a constant flow of oxygen directly into the breathing loop to replace volumes lost through user consumption and carbon dioxide absorption. Oxygen will continually flow from the restrictor at 1.90 lpm which 4-6 times greater than the metabolic consumption of oxygen by a human at rest. Metabolic consumption rates of oxygen by human subjects can be characterized as listed below.

Body at Rest	0.2 to 0.5 lpm
Light Work Load	0.8 to 1.0 lpm
Moderate Work Load	1.0 to 1.5 lpm
Heavy Work Load	1.5 to 2.0 lpm
Extremely Heavy Work Load	2.0 to 3.0+ lpm

Carbon Dioxide Scrubber Canister: The carbon dioxide scrubber canister will remove user-exhaled carbon dioxide through a chemical reaction. It is essential to remove the carbon dioxide from the breathing loop as it will become toxic to the user over time and will lead to poisoning. Carbon dioxide is a byproduct of the user metabolic consumption of oxygen. The chemical reaction of the carbon dioxide absorption will release heat and moisture into the breathing loop and transform the scrubbing media into calcium carbonate as shown by the reaction below.



Carbon Dioxide + Calcium Hydroxide Y Calcium Carbonate + Water

Inhalation Breathing Hose: The inhalation breathing hose is a flexible hose that will transfer carbon dioxide-free, cooled and condensed breathing air from the breathing chamber into the inhalation port of the facepiece.

C. High Pressure Plumbing

The high-pressure plumbing includes all components that are exposed to the high pressure oxygen stores. Referring to Figure 1 this includes the oxygen cylinder, oxygen cylinder pressure gauge, oxygen cylinder valve, pressure regulator and chest mounted pressure gauge. These components serve to reduce the stored oxygen high pressure to a usable pressure level, control the actuation of the oxygen stores and indicate the amount of remaining oxygen stores.

Oxygen Cylinder: The oxygen cylinder is a steel DOT approved pressure vessel that will contain the store of high-pressure oxygen in the respirator. The cylinder will hold 6.8 cubic feet of oxygen compressed to 2250 psi when fully charged. This amount of oxygen will support the full sixty-minute duration of the respirator. The cylinder shall only be charged with U.S.P. medical grade 100% oxygen and requires hydrostatic testing every five (5) years (unless stamped with a star figure in which case testing can be every ten (10) years) according to CGA requirements for steel cylinders. The cylinder is removable to permit recharging either in-house or by a third party.

Oxygen Cylinder Valve: The oxygen cylinder valve is attached directly to the oxygen cylinder and provides a mechanism for manually opening and closing the oxygen cylinder to the high pressure plumbing system.

Oxygen Cylinder Pressure Gauge: The oxygen cylinder pressure gauge is connected directly to the oxygen cylinder and will provide a visual indication of the amount of oxygen stored in the cylinder. The gauge will indicate the internal pressure of the cylinder regardless of the position of the oxygen cylinder valve. This provides constant indication of cylinder fill conditions.

Pressure Regulator: The pressure regulator consists of a pressure reducing mechanism and a 2-pin yoke. The pressure regulating mechanism will reduce the high pressure of the oxygen cylinder to approximately 120 psig for delivery into the low pressure plumbing system. The two-pin yoke consists of a standard CGA oxygen valve connection format and a threaded handle to lock the valve of the oxygen cylinder into position onto the pressure regulator.

Chest Mounted Pressure Gauge: The chest mounted pressure gauge mounts on the harness of the respirator and connects directly to the high pressure of the oxygen cylinder to provide the user with a real-time visual indication of remaining oxygen stores during use. Connection of the gauge to the oxygen cylinder is made via an armored plumbing line to protect it from damage during respirator use. A flow restrictor is employed between the gauge and the cylinder to prevent the sudden release of oxygen stores in the event the connecting line becomes severed. The gauge provides a direct indication of pressure remaining in the oxygen cylinder that can be translated into remaining respirator use time as listed below. A red area on the gauge dial indicates to the user when approximately fifteen-minutes of oxygen stores remain.

Gauge Reading, psi	Remaining Use Time, Minutes
2250	60
1700	45
1125	30
550	15

D. Low Pressure Plumbing

The low-pressure plumbing consists of all components that deliver the reduced pressure oxygen stores into the breathing loop and provide audible alarm features. Referring to Figure 1 this will include the bypass valve, alarm whistle and associated small diameter tubing.

Bypass Valve: The bypass valve is a manually operated pushbutton located on the exterior of the respirator housing and will provide unrestricted flow of oxygen into the breathing loop when depressed. The valve is intended for emergency uses only as described in the User Instruction Manual.

Alarm Whistle: The alarm whistle will provide an 92 dB audible signal for 20-30 seconds whenever remaining oxygen stores are 25% of full capacity. The alarm is a one-time signal that signals the user when approximately fifteen-minutes of oxygen remains. The alarm is situated between the low pressure and high-pressure plumbing components and functions on the differential pressure between the two systems.

Associated Plumbing: The associated plumbing of the low-pressure system is 1/8" or 3/16" diameter copper tubing that will connect the reduced pressure oxygen to the breathing loop and the alarm whistle.

IV. Turn-Around Maintenance Procedure

NOTE: Turn-Around Maintenance procedures should be performed as soon as possible after each use of the Biopak to provide for immediate reuse and to prevent the growth of biological organisms in non-disinfected equipment.

A. Turn-Around Maintenance Tag

The Turn-Around Maintenance Tag provides an indication of completed procedures and inspections for user verification before subsequent Biopak uses. Tags are supplied in bulk with each shipment of carbon dioxide absorbent and should be utilized throughout the procedures outlined in this section of the manual. Without the completed tag in place on the Biopak, the user will not know for certain that the Biopak is ready for use.

B. Biopak Disassembly

1. Use a sponge and mild soap to wipe clean the entire exterior of the Biopak and harness. Wipe dry or allow to air dry.
2. Remove the upper housing from the Biopak by disconnecting the latch to release and swing the housing up so that it can be lifted off of the hinge plates.
3. Disconnect the hoses from the facepiece by unthreading the hose connectors. Disconnect the connection and exhalation hoses from the breathing chamber by unthreading the worm gear clamps.
4. Inspect the anti-fog lens of the facepiece to verify that the perimeter seal is consistent and does not contain voids. Re-burnish the sealing edges if required.
5. Remove the stainless steel cover from the breathing chamber as outlined below.
 - a) Slide the snap latches of the cover to disengage them from the studs.
 - b) Pull up on the lip of the cover with the fingers while pushing down on the breathing hose stubs of the breathing chamber to remove the cover. Submit the cover to the washing and disinfecting procedure.

CAUTION: Do not use a screwdriver or any other instrument or tool to pry the cover away from the breathing chamber. Such action will risk damage to the top edge of the breathing chamber as well as possibly damage the breathing chamber o-ring seals.

6. Lift the carbon dioxide scrubbing canister out of the breathing chamber by lifting on the canister edge with the fingers and pressing down on the breathing chamber rim with the thumbs.

CAUTION: Do not use a screwdriver or any other instrument or tool to pry the canister out of the breathing chamber. Such action will risk damage to the top edge of the breathing chamber as well as possibly damage the breathing chamber o-ring seals.

7. Remove the carbon dioxide scrubbing canister from the Biopak work area and remove the top cover by pushing the latch away from the center stud. It is best to remove the top cover over a waste bin since the scrubbing media is in granular form and may spill out. Submit the cover to the washing and disinfecting procedure.

8. Remove the foam pad from the scrubber and dump the internal granular contents into a suitable waste bin. The granular scrubbing media is spent soda-lime that is has been converted to limestone and is safe to dispose in regular trash. Submit the canister body and foam pad to the washing and disinfecting procedure.

CAUTION: Always wear rubber gloves and safety glasses when working with soda lime. Reference Appendix B for details on the hazards of soda lime, proper handling and first aid measures.

9. Remove the oxygen cylinder from the Biopak by rotating the regulator yoke handle in a counterclockwise direction to loosen the connection. Guide the cylinder up off of the center post and pins and out of the yoke. Remove the sealing washer that seals the cylinder valve to the yoke and retain for reuse. Submit the oxygen cylinder to the oxygen cylinder filling procedure. It is acceptable to leave the oxygen cylinder in place during the duration of the washing and disinfecting procedure.

WARNING: Before removing the oxygen cylinder, verify that the cylinder valve is closed, that the chest mounted pressure gauge reads 0 psi, and depress the bypass valve to relieve any internal pressure.

10. Disconnect the two copper plumbing lines to the breathing chamber by pulling away the anti-rotation collar and unthreading the two hand knobs of the connections. Locate and save the o-ring seals that are seated on the face of each plumbing connection. Remove the breathing chamber from the Biopak by unthreading the four screws and washers located in the corners of the chamber. Retain the screws and washers for future reuse and submit the breathing chamber to the washing and disinfecting procedure.

C. Washing and Disinfecting

1. Complete the Biopak disassembly procedure before washing and disinfecting.
2. Prepare a disinfecting solution by adding one (1) packet of disinfectant agent, part number B6-02-5000-42-0, per one (1) gallon of warm, clean water.

CAUTION: Do not substitute any other disinfectant agent. Other agents may contain alcohol or chlorine that can deteriorate facepiece lens and rubber components.

3. Place the facepiece, the breathing chamber lid and all the hoses into the disinfecting solution for a minimum of ten minutes. Rinse the components thoroughly with the solution insuring that all surfaces have become wetted. Be sure to introduce the solution into the internal volume of the breathing chamber.

NOTE: Do not wash and disinfect the carbon dioxide scrubber components until after washing all other components to avoid contact of absorbent granules.

4. Cover the demand housing, located in the center of the breathing chamber, with a finger cot.

5. Pour disinfectant solution into the tube stubs of the breathing chamber. Vigorously shake the breathing chamber with the tube stub end blocked to spread the solution throughout the chamber. Allow all internal breathing chamber surfaces to remain wetted with the cleaning solution for a minimum of ten-minutes.

CAUTION: It is advised not to totally submerge the breathing chamber into the disinfectant solution to avoid contact of the solution with the demand housing flow restrictor. Contact of the solution with the flow restrictor may cause restrictor clogging.

6. Remove the components from the solution and rinse several times in clean, fresh water. Set the rinsed components aside to air dry; or, dry the components with a hair drier set for cool temperature.
7. Place the carbon dioxide scrubber canister body, lid and pad into the solution for a minimum of ten minutes. Rinse the components thoroughly with the solution to insure that all surfaces become wetted.
8. Remove the carbon dioxide scrubber components from the solution and rinse several times in clean, fresh water. Allow the components to air-dry or dry them with a hair drier set for cool temperature.
9. Remove the finger cot from the breathing chamber demand housing; or, remove the demand housing wash plug and re-install the restrictor fitting to the top of the demand housing.
10. Check the "WASHING/DISINFECTING" box on the Turn-Around Maintenance Tag.

D. Oxygen Cylinder Charging

1. **For Charging of the Oxygen Cylinder by Third Parties:** Verify that the cylinder valve and seat are clean and cover with a clear plastic bag. Secure the bag with a rubber band or tie. Supply the cylinder to the third party filling vendor with instructions to fill between 2025 and 2474 psig, as read by the cylinder gauge after the cylinder has cooled to 70°F, with U.S.P. medical grade oxygen.
2. **For In-House Charging:** Follow the guidelines outlined below.
 - a) The filling area should be completely free of any grease or oil products. If the filling is done in a small confined area, adequate ventilation should be provided to prevent the build up of oxygen and the formation of an oxygen rich atmosphere.
 - b) Only U.S.P medical grade oxygen is to be used to fill Biopak oxygen cylinders. Other grades of oxygen may contain impurities and excess moisture that can affect the cylinder as well as the plumbing in the Biopak.
 - c) To further protect the oxygen supply from possible contamination from moisture or dust, it is recommended that each booster pump be equipped with a filter/drier assembly installed on the gas inlet side of the booster pump. The filter shall be serviced at regular intervals as required.
 - d) Before filling any cylinder visually inspect the cylinder under a bright light for signs of physical damage and the accumulation of contaminants such as dirt, lint, grease or oil. Clean all contaminants from the cylinder before proceeding with filling. Discovery of any external damage to the cylinder will require hydrostatic testing at a test facility as per CGA regulations for steel cylinders.
 - e) Before filling any cylinder inspect the hydrostatic test date stamped on the cylinder. If the test date is over five (5) years old the cylinder may not be refilled. Have the cylinder hydrostatically tested by an approved test facility or Biomarine as per CGA regulations for steel cylinders.

- f) Make a special effort to prevent cylinders from being drained below 500 psig, as indicated by the cylinder pressure gauge, at all times to reduce the possibility of external contamination migration into the cylinder.
- g) Oxygen cylinders that have pressure gauge readings of 0 psig must be purged and pulled into a vacuum to remove all traces of moisture before filling. It is suggested that these cylinders be returned to Biomarine to insure proper purging and vacuum application.
- h) Prior to connecting the cylinder to the refill pump the cylinder valve should be briefly opened to purge the valve seat of accumulated dust and/or moisture. Do not direct the valve opening towards the face or skin when opening.
- i) Oxygen cylinders should be filled and stored at ambient temperatures maintained at 70°F. Filling a cylinder at high temperatures can result in final fill levels several hundred psig below the target pressure once the cylinder cools. Conversely, filling the cylinder at low temperatures may result in a final fill pressure of several hundred psig above the target pressure once the cylinder warms. The variation of oxygen pressure with temperature is extreme and can result in hazardous conditions. Therefore it is imperative that the oxygen cylinder storage temperature be maintained as close as possible to 70°F at all times.
- j) During cylinder filling the temperature of the cylinder will rise in proportion to how quickly the cylinder is filled. If the booster pump is heavily loaded, the cylinder temperature will rise and cause increased oxygen expansion and pressure. Therefore a two-stage process is required to properly fill the oxygen cylinder. After filling the cylinder to rated service pressure stamped on the cylinder, the cylinder should be allowed to cool to approximately 70°F. This will normally require a 15-20 minute cool down period if the cylinder is left in 70°F ambient temperatures. The pressure as indicated on the cylinder pressure gauge will drop during this cool down period. Once the cylinder has cooled, a second fill stage to the proper fill pressure can be made.
- k) The above guidelines must be followed in order to safely fill the oxygen cylinder. Oxygen can be a dangerous substance when not properly handled due its oxidation and flammability enhancement properties. For further details of oxygen cylinder filling and supply of proper filling equipment, contact the local Biomarine representative for assistance.

E. Biopak Re-Assembly

1. Position the washed, disinfected and dried breathing chamber into position in the lower housing of the Biopak. Be sure to properly position the diaphragm spring over and around the vent valve of the breathing chamber during installation. Secure the breathing chamber into position using the four screws and washers. Reconnect the two copper plumbing lines and the lightly greased o-ring seals to the fittings of the breathing chamber by hand-tightening each connection hand knob and re-installing the anti-rotation collar over the installed connections.
2. Connect the inhalation hose, identified by a green band, to the inhalation hose port of the of the center section, identified by a green band, using a worm gear clamp to secure.
3. Connect the exhalation hose the exhalation hose, identified by a red band, to the exhalation hose port of the center section, identified by a red band, using a worm gear clamp to secure.
4. Connect the free ends of the inhalation and exhalation hoses together with a hose coupling fitting.
5. Verify that the oxygen cylinder sealing washer is clean and install it onto the center post of the regulator. Guide a recharged oxygen cylinder, or a charged test cylinder, into the

regulator yoke and seat it onto the center post and pins of the regulator. Tighten the regulator yoke against the cylinder to secure the connection. Secure the cylinder in the Biopak with the Velcro strap.

F. Flow Test

1. Slide a test flow meter, part number B6-02-5000-16-0, over the demand valve housing located in the center of the breathing chamber well.
2. Insert a wooden tongue depressor into one of the breathing chamber slots located around the chamber rim and press down to move the diaphragm away from contact with the well. Wedge the tongue depressor in the slot to maintain its position.
3. Open the oxygen cylinder valve and verify a flow reading on the flow meter of at least 1.90 lpm with the oxygen cylinder at 2250 psig. If the flow meter does not read at least 1.90 lpm reference the Troubleshooting section of this manual.
4. Close the oxygen cylinder valve and remove the flow meter.
5. Check the "FLOW TEST" box of the Turn-Around Maintenance Tag.

G. Carbon Dioxide Absorbent Charging and Installation

CAUTION: Always wear rubber gloves and safety glasses when working with Soda-Sorb. Reference Appendix B for details on the hazards of Soda-Sorb, proper handling and first aid measures.

1. Complete the washing and disinfecting procedure of all carbon dioxide scrubber components before proceeding with recharging.
2. Fill the canister to the fill line indicator using a single bag of Soda-Sorb, B5-01-3000-00-0.
3. Shake the canister back and forth on a smooth surface to promote settling of the absorbent into the canister.
4. Add additional absorbent as required to fill to the indicated level.

WARNING: Do not expose the absorbent material to the ambient atmosphere for more than a total of one (1) hour during recharging and/or servicing. Excessive exposure of the absorbent to ambient atmosphere will reduce the absorbent efficiency.

WARNING: The carbon dioxide absorbent material has a shelf life of two (2) years when sealed in its shipping container. Once the bag has been opened promptly discard any unused portions of Soda-Sorb remaining in the bag.

5. Inspect the foam pad and verify that it not compressed. Replace any foam pad that is less than 1/8" thick over the absorbent coverage area or 1/32" on the outside diameter. Any foam pad that does not overlap the outer edge of the canister body should also be replaced.
6. Position the foam pad on top of the canister so that the center stud protrudes through the center hole of the pad and the pad overlaps the outside diameter of the canister body.
7. Install the scrubber cover onto the top of the foam pad and secure into position by sliding the snap latch onto the center stud of the canister body.

8. With the cover installed and locked into position, shake the scrubber assembly. If properly filled there shall be no sounds of absorbent shifting during shaking. The foam pad should extend through the holes of the cover.
9. Inspect the large o-ring seal located on the inside diameter of the breathing chamber for nicks, cuts or abrasions according to guidelines set forth in Section VI.B.. Replace the o-ring if signs of damage are evident. Lightly grease the o-ring with Dow-111 o-ring lubricant.
10. Position the charged carbon dioxide scrubber into the center of the breathing chamber well and press straight down and into the well until the scrubber bottoms out.
11. Remove and inspect the large o-ring seal located on the outside diameter of the breathing chamber for nicks, cuts or abrasions according to guidelines set forth in Section V.B.. Replace the o-ring if signs of damage are evident. Lightly grease the o-ring with Dow-111 o-ring lubricant and re-install.
12. Position the washed, disinfected and dried breathing chamber cover over the center of the breathing chamber and press straight down so that the chamber studs protrude through the cover through holes. Slide the snap latches of the cover onto the studs to secure the cover in place.
13. Check the "*CARBON DIOXIDE ABSORBENT REPLACEMENT*" box on the Turn-Around Maintenance Tag.

H. Facepiece Concerns

1. Complete the washing and disinfecting procedure to the facepiece before proceeding.
2. Inspect the facepiece rubber components for signs of wear, cuts, nicks or abrasions. Replace the facepiece as required.
3. Inspect the perimeter seal of the anti-fog lens. Re-burnish the seal edges if voids or gaps are evident.
4. Use the anti-fog cloth, part number B6-02-5000-08-0, to apply a heavy coat of anti-fog agent onto the exposed inside surface of the facepiece lens and/or anti-fog lens. Best results are gained by allowing the anti-fog agent to completely dry on the facepiece before the next use.

CAUTION: Do not ingest the anti-fog solution or allow the anti-fog solution to contact the eyes. Refer to Appendix B for handling and first aid measures.

5. Check the "*ANTI-FOG AGENT APPLICATION*" box of the Turn-Around Maintenance Tag.

I. Final Re-Assembly

1. If a test oxygen cylinder has been installed, replace it with a freshly charged oxygen cylinder. Open the cylinder valve and listen for leaks, the alarm whistle chirping and verify that the chest-mounted pressure gauge has the same reading as the oxygen cylinder pressure gauge after 90 seconds. Close the cylinder valve after testing.
 - a) If leaks are heard try reseating the oxygen cylinder on the regulator and inspect the sealing washing between the regulator and the cylinder. Replace the washer if damaged or if leaking persists.
 - b) If the alarm whistle does not chirp upon opening of the cylinder valve replace the alarm whistle.
 - c) If the chest mounted pressure gauge reading is incorrect replace the chest-mounted gauge and pressure line.
2. Verify that the oxygen cylinder is securely fastened to the Biopak at the regulator and with the Velcro strap. Verify that the pressure gauge of the cylinder reads between 2025 and 2474 psig. Check the *OXYGEN CYLINDER REPLACEMENT* box on the Turn-Around Maintenance Tag.
3. Reinstall the upper housing to the Biopak and secure into position using the flexible draw latch.
4. Sign and date the Turn-Around Maintenance Tag and attach it to the handle of the oxygen cylinder valve.
5. Place the Biopak in its designated storage location. The Biopak is now ready for reuse.

v. Periodic Long-Term Maintenance

In addition the normal Turn-Around Maintenance, the Biopak should be visually inspected, flow tested and high and low pressure tested on a monthly basis for units that are in constant use. Biopaks that are in extended storage may be visually inspected, flow tested and high and low pressure tested on a quarterly basis provided the following conditions have been met:

- Biopak is stored in an acceptable environment between 32°F (0°C) and 85°F (30°C) away from contact with contaminants such as dirt, liquids, etc.
- Turn-Around Maintenance has been performed after each use in a timely manner.
- Biopak is stored sealed with all connections tight and the breathing hoses connected together with the hose coupling fitting.

NOTE: A properly maintained and sealed Biopak can be stored up to one (1) year and placed directly into use. Only under circumstances where the Biopak is to be stored for a 6-12 month period may the Periodic Long-Term Maintenance schedule be extended to biannually or annually. Periodic Long-Term Maintenance must be performed on a monthly basis for Biopaks that have regular (daily, weekly or monthly) use schedules. Maintenance schedules should be tailored to the use schedule of the Biopak.

After completing the visual inspection, the flow test, the high pressure testing and the low pressure testing, sign and date the back of the Turn-Around Maintenance Tag and complete the Maintenance Log Sheet, reference Appendix A, to maintain a record of scheduled maintenance.

A. Visual Inspection

1. Remove the upper housing from the Biopak.
2. Visually inspect all components and housings for signs of wear, abuse, damage or loose connections or parts that may impair the ability of the Biopak to function under use.
3. Repair or replace any component that appears questionable.
4. Replace the upper housing onto the Biopak.

B. High Pressure Leak Testing

1. Place the Biopak onto a flat surface and remove the upper housing. Verify that the breathing hoses are connected together with the hose coupler fitting.
2. Install a fully charged oxygen cylinder into the Biopak if one is not already in place.
3. Remove the breathing chamber lid and the carbon dioxide scrubber canister.
4. Wedge a wooden tongue depressor into one of the slots along the edge of the breathing chamber to push the diaphragm away from the internal breathing chamber well.
5. Turn on the oxygen cylinder valve.
6. Inspect each plumbing connection joint with Leak-Tec solution, part number B5-01-3000-03-0. Inspection is performed by applying the Leak-Tec solution to each joint, allowing the solution to sit for a minimum of one minute and then visually inspecting each joint for signs of constant bubble formation.
7. Tighten or replace any plumbing joint that shows signs of leakage.
8. Remove the wooden tongue depressor, turn off the oxygen cylinder and replace the carbon dioxide scrubber canister, breathing chamber lid and upper housing.

C. Low Pressure Leak Testing

1. Place the Biopak onto a flat surface and remove the upper housing.
2. Disconnect the breathing hoses from the hose coupler fitting and connect the hoses to the leak test fixture, part number B6-02-5000-29-0.
3. Turn the Biopak over and insert a test key, part number B6-02-5000-17-0, into the slotted hole on the rear of the lower housing and turn the key $\frac{1}{4}$ turn to lock into position.
4. Turn the Biopak back over and open the oxygen cylinder valve. Use the bypass valve to inflate the balloon of the leak test fixture to an approximate 45° angle. If the balloon over inflates it can be vented through the vent valve of the test fixture.

WARNING: Severe over inflation of the test balloon can cause damage to the balloon itself and to the vent valve of the breathing chamber.

5. Close the oxygen cylinder valve and depress the bypass valve to vent the internal pressure of the Biopak. If gas escapes around the red pushbutton of the bypass valve the o-ring of the button will require replacement.
6. Observe the test balloon for a period of 2 minutes. The balloon should not significantly droop from 45° to 0° during the 2-minute period. A droop to 35° is acceptable and only sagging to 0° is considered significant. If a significant droop is detected then inspect all hose connections and the breathing chamber cover for leakage and repair.
7. Disconnect the test fixture from the breathing hoses and reconnect them together with the hose coupler fitting.
8. Remove the test key from the rear of the Biopak and reinstall the upper housing.

WARNING: Failure to remove the test key from the Biopak will result in excessively high breathing resistance, improper Biopak function and may damage the diaphragm of the breathing chamber.

D. Flow Testing

1. Remove the upper housing, breathing chamber cover and carbon dioxide scrubber from the Biopak.
2. Slide a test flow meter, part number B6-02-5000-16-0, over the demand valve housing located in the center of the breathing chamber well.
3. Insert a wooden tongue depressor into one of the breathing chamber slots located around the chamber rim and press down to move the diaphragm away from contact with the well. Wedge the tongue depressor in the slot to maintain its position.
4. Open the oxygen cylinder valve and verify a flow reading on the flow meter of at least 1.90 lpm with the oxygen cylinder at 2250 psig. If the flow meter does not read at least 1.90 lpm reference the Troubleshooting section of this manual.
5. Close the oxygen cylinder valve and remove the flow meter.
6. Replace the carbon dioxide scrubber, the breathing chamber cover and the upper housing into the Biopak.

E. Optional Facepiece Fit Testing

The Biopak is a positive pressure device that will leak outward in the event of poor facepiece sealing. Leakage of gas from around the facepiece seal will significantly decrease the duration of the Biopak during use. The procedure outlined below is provided as a guide for user testing to achieve and verify a good facepiece seal.

1. Construct a test connector consisting of a stopper with a hole through it sized to fit into the hose connection ports of the facepiece and a length of tubing. The tubing should connect to the stopper hole on one end and a pressure measuring device on the other end such as a water manometer capable of measuring 6" water column.
2. Don the facepiece without the breathing hoses attached and perform the negative and positive tests of facepiece donning.
3. Connect the test fixture to the exhalation port, identified by a red band, of the facepiece.
4. Take a deep breath and slowly exhale into the facepiece while observing the pressure measuring device. Note the reading of the pressure measuring device when the facepiece seal begins to leak. Stop exhaling and note where the pressure measuring device reading settles. For a good facepiece seal the pressure measuring device should indicate a pressure reading of at least 6" water column.
5. Remove the test connection and doff the facepiece.

VI. General Service Procedures

A. Scheduled Component Replacement

In order to maintain the Biopak in peak condition it is recommended by the manufacturer that the below listed components be replaced as listed.

Part Description	Part Number	Replacement Frequency
Carbon Dioxide Scrubber Foam Pad	B2-02-7100-10-0	every 20 uses
Facepiece Anti-Fog Lens Insert	B2-02-0000-30-0	every 20 uses
Oxygen Cylinder Sealing Washer	B3-03-0006-01-0	every 50 uses
Breathing Chamber ID O-Ring Seal	B4-04-7060-02-0	every 50 uses
Breathing Chamber OD O-Ring Seal	B4-04-7060-03-0	every 50 uses
Bypass Tube O-Ring Seal	B4-04-7070-02-0	every 20 uses
Demand Tube O-Ring Seal	B4-04-7070-00-0	every 50 uses

The Biopak is designed for no mandatory component replacement during its lifetime. However, certain components will require replacement over time due to wear or damage. The Long-Term Maintenance procedures will aid the Benchman in the identification of worn or damaged components. It is recommended that after a period of five (5) years the Benchman pay particular attention and provide additional inspection to the parts listed below for signs of wear or damage.

Breathing Diaphragm: Remove the breathing chamber and disconnect the diaphragm from the center section housing by unthreading the diaphragm worm gear clamp. Inspect the diaphragm for signs of wear, cracking or rot. Leak testing procedures will indicate leakage whenever the diaphragm has been perforated or torn.

Facepiece: Inspect the rubber portions of the facepiece for signs of wear, tears, rips, cracking or rot. The mask fit test will identify if the face seal has degraded. Inspect the anti-fog lens insert for signs of cracking, crazing, hazing or wrinkling. Inspect the seal around the perimeter of the anti-fog lens to insure there are no voids. Replace the lens if required.

Breathing Hoses: Inspect for signs of wear, cracking, stiffness, tears or rot. The breathing hoses can incur substantial abuse during use due to contact with abrasive surfaces such as rock walls, concrete walls, etc. Leak testing procedures will indicate leakage if the hoses have become perforated or torn.

O-Ring Seals: In general, if the Biopak has passed the high and low pressure leak testing procedures then it can be assumed that the o-ring seal integrity is acceptable. It is recommended to perform the System Lubrication procedure at least once a year after the Biopak has aged five (5) years.

B. System Lubrication

Proper lubrication of all o-ring seals is essential to the reliable operation of the Biopak. An o-ring seal that has degraded will appear as leakage at its location during high or low pressure leak testing. O-ring damage can result from wear, misalignment during seating or improper use of lubricant. Observe the following precautions when servicing o-rings:

- Never pry an o-ring from its seat with a screwdriver. This can damage both the o-ring and the seat. Always **carefully** remove an o-ring with a dull pointed pick tool.
- Do not attempt to lubricate an o-ring while it remains in its seat. This may result in excessive application of the lubricant and incomplete coating of the o-ring.
- Do not apply heavy coats of lubricant to the o-ring. Excessive lubrication does not provide greater sealing capability and may result in lubrication migration away from the o-ring and into the breathing loop. A properly lubricated o-ring should have an even coating that appears as a dull sheen on the entire surface with no lumps or clumps.
- When lubricating an o-ring, use the thumb and forefinger to work the lubricant over all surfaces while feeling for nicks or cuts. Replace any o-ring that has tears, rips, uneven spots, nicks, cuts, rough spots or abrasions.
- *Cristo-Lube (MCG-111)* or *Dow-111 Silicone Lubricant* are the only lubricants approved by the manufacturer for use in the Biopak. Do not substitute any other lubricant.

WARNING: Do not use an oil-based lubricant or any other lubricant on the o-ring seals other than *Cristo-Lube (MCG-111)* or *Dow-111 Silicone Lubricant*. The use of other lubricants not approved by the manufacturer may result in fire hazards in the presence of the enriched oxygen atmosphere of the Biopak.

WARNING: *ALTHOUGH THE OXYGEN CYLINDER SEALING WASHER SERVES THE SAME PURPOSE AS AN O-RING SEAL IT SHOULD NEVER BE LUBRICATED.* Lubrication of the sealing washer may result in regulator stem clogging, rapid accumulation of dirt and will present a fire and explosion hazard due to the present of the high pressure, enriched oxygen atmosphere.

It is recommended to inspect and lubricate the below listed o-rings after every 50 uses of the Biopak. O-ring locations and part numbers can be referenced on the Illustrated Parts Lists of this manual.

Breathing Chamber O-Rings: The large diameter o-rings that seal the breathing chamber housing to the breathing cover and the carbon dioxide scrubber canister, as well as the copper tubing face seal o-rings to the center section, will experience much abuse during repeated Turn-Around Maintenance procedures. These o-rings shall be lubricated with either approved lubricant.

Vent Valve O-Rings: Reference the Diaphragm Assembly Illustrated Parts Lists (Section X.G.) for the location of the four o-ring seals. These seals may be lubricated with either approved lubricant.

Other O-Rings: The remaining o-rings of the Biopak will not be exposed to wear conditions and should not require regular lubrication. Problems with these o-rings will surface during high and low pressure leak testing. Should one of the remaining o-rings require replacement, reference the Illustrated Parts Lists for its location and replacement part number. Follow all guidelines presented above and use only the lubricants approved by the manufacturer as listed below.

WARNING: Use only the approved lubricant as listed below when servicing o-rings. Use of the Dow-111 lubrication where Cristo-Lube is specified may result in poor Biopak function.

General O-Ring Location	Reference Parts List	Lubricant Use
Bypass Valve	Section X.E.	Cristo-Lube
Alarm Whistle Assembly	Section X.F.	Cristo-Lube
Flow Restrictor O-Ring Seal	Section X.G.	Cristo-Lube
Connector Tube O-Ring Seal	Section X.G.	Cristo-Lube

C. Oxygen Cylinder

There are no serviceable components on the oxygen cylinder. The cylinder should be inspected regularly for signs of exterior damage. Note that the cylinder is a DOT approved pressure vessel and will require hydrostatic testing every five (5) years. Every cylinder will have the date of the last test marked on the cylinder itself or on its label. Testing shall be performed at a competent testing facility. Contact the local Biomarine representative, the local facility that may fill the oxygen cylinder or the factory for the location of a competent test facility.

NOTE: It is unlawful to utilize an oxygen cylinder that has exceeded the three (3) year period since the last hydrostatic test date.

D. Regulator Assembly

The regulator assembly can not be serviced or repaired in the field. In the rare instance of regulator failure, as marked by failure of the flow test after replacement of the flow restrictor and demand valve, the regulator will require removal from service and replacement. The procedure for regulator replacement is outlined below.

1. Be sure that the oxygen cylinder valve is closed by rotating it to its full clockwise position.
2. Verify that all pressure has been removed from the Biopak system as indicated by a zero psi reading on the chest mounted pressure gauge and by depressing the bypass valve to relieve any internal pressure.
3. Remove the oxygen cylinder from the regulator yoke by disconnecting the Velcro strap around the cylinder and loosening the regulator yoke. Lift the cylinder off of the regulator center post and pins and slide the cylinder from the Biopak.
4. Reference the Top Assembly Illustrated Parts List, Section X.A and Pneumatic Assembly Illustrated Parts List, Section X.D. Disconnect the copper high-pressure tube assemblies from their connections to the regulator using two 7/16" and one 1/2" open-end wrenches.
5. Unthread the three screws holding the regulator and external regulator support plate to the lower housing.
6. Carefully lift the regulator and yoke assembly from the lower housing.

7. Position the replacement regulator into the lower housing and re-connect all plumbing lines as depicted by the Pneumatic Assembly Illustrated Parts List, Section X.D.
8. Secure the regulator to the lower housing using the three screws as referenced by the Top Assembly Illustrated Parts List, Section X.A.
9. Reinstall the oxygen cylinder and perform the Period Long-Term Maintenance procedures.

E. Bypass Valve Assembly

The bypass valve will require service if the valve fails to provide emergency flow when depressed or if gas leaks around the perimeter of the pushbutton. If the valve will not function correctly the valve core most likely requires replacement. If leakage exists around the perimeter of the pushbutton the o-ring seal most likely requires replacement. Reference the procedures outlined below and the Bypass Valve Illustrated Parts List, Section X.E, to service the bypass valve.

Replacing the Valve Core:

1. Verify that the oxygen cylinder valve is off, rotated to its full clockwise position, and the chest mounted pressure gauge reads zero psi. Depress the bypass valve to relieve any internal pressure in the Biopak.
2. Use the bypass valve wrench, included in the service kit, to remove the valve guard and washer from the lower housing. The pushbutton, o-ring, mounting washer and spring will now fall out of the valve assembly.
3. Use the valve core tool, provided in the service kit, to remove the valve core from the center core of the valve body. Immediately discard the valve core.
4. Install a replacement valve core into the center of the valve body. Proper installation depth is achieved when resistance is felt during rotation.
5. Reassemble the bypass valve spring, o-ring, pushbutton, washer and guard into the valve body using the bypass valve wrench. Tighten the guard until snug.
6. Perform the Periodic Long-Term procedures.

Replacing the Bypass Valve O-Ring, Part B4-04-7070-07-0

1. Verify that the oxygen cylinder valve is off, rotated to its full clockwise position, and the chest mounted pressure gauge reads zero psi. Depress the bypass valve to relieve any internal pressure in the Biopak.
2. Use the bypass valve wrench, included in the service kit, to remove the valve guard and washer from the lower housing. The pushbutton, mounting washer, o-ring and spring will now fall out of the valve assembly.
3. Remove the o-ring seal from the groove on the stem of the pushbutton. Immediately discard the o-ring.
4. Lubricate a replacement o-ring with Cristo-Lube lubricant according to guidelines presented in Lubrication, Section VI.B.
5. Reassemble the bypass valve spring, o-ring, pushbutton, washer and guard into the valve body using the bypass valve wrench. Tighten the guard until snug.
6. Perform the Periodic Long-Term Maintenance and Turn-Around Maintenance procedures.

F. Alarm Whistle Assembly

If the alarm whistle does not provide a “chirp” when the oxygen cylinder valve is initially opened or if the whistle is difficult to hear it will require adjustment. Alarm whistles that do not function at all should be replaced and the defective whistle returned to the factory.

To Adjust the Alarm Whistle Tone:

1. Loosen the set screw in the tone arm holder and remove the tone arm.
2. Open the oxygen cylinder valve and verify that gas is escaping from the small hole in the side of the alarm body when the cylinder is opened. The gas flow will only last for a few seconds. If gas is escaping then continue with this procedure. If gas is not escaping, the alarm whistle assembly will require replacement.
3. Close the oxygen cylinder valve.
4. Reposition the tone arm into the holder so that the notch in the arm covers approximately $\frac{1}{2}$ of the small hole in the alarm body. Tighten the set screw in the tone arm holder to secure.
5. Open the cylinder valve and verify that the alarm whistle produces a brief “chirp”.
6. Repeat the procedure to adjust the tone arm so that it will produce the loudest possible tone. If the whistle will not produce the desired start up “chirp” then replace the alarm whistle assembly.

To Replace the Alarm Whistle Assembly:

1. Verify that the oxygen cylinder valve is closed, rotated to its full clockwise position, and that the chest mounted pressure gauge reads zero psi.
2. Referencing the Top Assembly Illustrated Parts List, Section X.A., remove the alarm whistle mounting clamp by unthreading the screw and nut from the lower housing.
3. Disconnect the copper high-pressure tube assembly from the bottom of the alarm whistle assembly using two $\frac{7}{16}$ ” open-ended wrenches.
4. Disconnect the copper low-pressure tubing from the top of the alarm whistle assembly using two $\frac{7}{16}$ ” open-ended wrenches.
5. Reconnect the plumbing lines to the replacement alarm whistle.
6. Position the replacement alarm whistle into the lower housing so that the tone arm and holder extend out through the slot in the lower housing.
7. Secure the alarm whistle to the lower housing using the screw and hex nut.
8. Open the valve of the oxygen cylinder and verify the start up “chirp”. Readjust the tone arm as required.
9. Perform the Periodic Long-Term Maintenance procedures.

G. Flow Restrictor Assembly

Should the Biopak fail the flow test of the Turn-Around or Periodic Long-Term Maintenance procedures, the flow restrictor located in the demand housing of the breathing chamber may require replacement. Reference the procedure outlined below and the Breathing Chamber Illustrated Parts List, Section X.J., to replace the flow restrictor.

To Replace the Flow Restrictor Assembly:

1. Verify that the oxygen cylinder valve is closed, rotated to its full clockwise position, and the chest-mounted pressure gauge reads zero psi. Depress the bypass valve to relieve any internal pressure in the Biopak.
2. Remove the upper housing, breathing chamber lid and carbon dioxide scrubber canister from the Biopak.

CAUTION: Do not use any tools to pry the breathing chamber cover or the carbon dioxide scrubber canister from the breathing chamber. Damage may occur to the o-ring seals or the components themselves. Proper removal of the cover and scrubber is made by pulling up on the edge of the component with the fingers while pushing down with the thumbs on either the breathing hose stubs or rim of the breathing chamber.

3. Use a 9/16" open ended wrench to remove the flow restrictor fitting from the top of the demand housing located in the center of the breathing chamber well.
4. Remove the o-ring seal from the flow restrictor fitting. Inspect the o-ring for signs of abrasions, extrusion, deformation or tears. Replace the o-ring if necessary. Immediately discard the flow restrictor fitting.
5. Install the existing or replacement o-ring into the groove of the replacement restrictor fitting. **Do not lubricate the o-ring.**
6. Reinstall the replacement fitting and o-ring into the top of the demand housing using the 9/16" open-end wrench. Tighten snugly.
7. Perform the flow test of the Period Long-Term Maintenance procedures.
8. Replace the carbon dioxide scrubber canister, the breathing chamber cover and the upper housing.

H. Breathing Chamber Assembly

Maintenance to the breathing chamber assembly may involve replacement of the diaphragm, replacement of the vent valve, replacement of the demand valve, replacement of the anti-anoxia valve or replacement of the flow restrictor. The replacement of these components may be required should the Biopak fail the flow test, the high-pressure leak test or the low-pressure leak test.

To Replace the Diaphragm and/or Vent Valve Components, Reference the Breathing Chamber and Diaphragm Assembly Illustrated Parts Lists, Section X.F. and G.:

1. Remove the upper housing from the Biopak.
2. Disconnect the hoses to the breathing chamber by unthreading the worm gear hose clamp.
3. Disconnect the two copper plumbing lines from the chamber by removing the anti-rotation collar and unthreading each connection's hand nut. Retrieve the o-ring seal from each connection and inspect for signs of damage or wear. Replace if necessary.

4. Release the breathing chamber from the lower housing by removing the four anchor screws and washers.
5. Lift the entire breathing chamber out of the Biopak.
6. Turn the breathing chamber onto its cover and remove the large worm gear clamp that holds the diaphragm in place.
7. Pull the diaphragm from the breathing chamber by its edge.
8. Use the vent valve wrench, supplied with the service kit, to disassemble the vent valve components from the center of the diaphragm. Discard the damaged diaphragm.
9. Clean all components of the vent valve and inspect. Replace any o-ring seal or component that shows signs of wear or damage. Re-lubricate the o-rings as per the Lubrication guidelines, Section VI.B..
10. Position the vent valve cap into the through hole of the replacement diaphragm so that the smooth flat surface of cap is on the same side of the diaphragm as the guide plates.
11. Place the red vent spring onto the center screen of the cap and position the secondary seat and its o-ring seal on top of the spring.
12. Carefully thread the secondary body and its o-ring seal onto the cap threads to hand-tight. Be sure that the spring is properly seated in the seat and the seat button extends through the center through hole of the body.
13. Position the silver vent spring on top of the secondary seat button and position the primary seat and its o-ring seal on top of the spring.
14. Secure into position by threading the primary body and its o-ring onto the threads of the secondary body making sure that the spring and primary seat are properly positioned.

WARNING: DO NOT utilize the vent valve wrench to tighten the vent valve secondary and primary body threaded connections. The connections only need to be made hand-tight to generate the required sealing force. Excessive force generated from over tightening may cause component damage and failure during use.

15. Press the button of the primary seat and verify that the vent valve opens easily and completely.
16. Reinstall the diaphragm into the underside of the breathing chamber so that the vent valve button is in view and the diaphragm guide plates are aligned with the breathing chamber mounting feet. Installation of the diaphragm is best achieved by first slipping a portion of the diaphragm over the chamber edge, holding that portion in position and slowly easing the remaining portions of the diaphragm over the remainder of the chamber.
17. Inspect the diaphragm position and verify that the edge of the diaphragm is positioned against the first shoulder of the breathing chamber wall over the entire diaphragm circumference.
18. Secure the diaphragm into position using the large worm gear clamp. It is suggested that the screw head of the worm gear clamp be located in the 10 o'clock position of the breathing chamber.

19. Turn the breathing chamber over and position it into the well of the lower housing making sure that the diaphragm spring is properly positioned over the vent valve.
20. Secure the breathing chamber to the lower housing using the four anchor screws and washers.
21. Re-install the copper plumbing connections to the breathing chamber by positioning a lightly greased o-ring seal into position and hand-tightening each connection knob. Secure the hand knobs of the connections by installing the anti-rotation collar.
22. Reconnect the hoses to the breathing chamber and secure each with a worm gear hose clamp.
23. Perform the Periodic Long-Term Maintenance procedures, Section V..
24. Replace the upper housing onto the Biopak.

To Replace the Demand Valve, Reference the Breathing Chamber Illustrated Parts List, Section X.F.:

1. Remove the upper housing from the Biopak.
2. Disconnect the hoses to the breathing chamber by unthreading the worm gear hose clamp.
3. Disconnect the two copper plumbing lines from the chamber by removing the anti-rotation collar and unthreading each connection's hand nut. Retrieve the o-ring seal from each connection and inspect for signs of damage or wear. Replace if necessary.
4. Release the breathing chamber from the lower housing by removing the four anchor screws and washers.
5. Lift the entire breathing chamber out of the Biopak.
6. Turn the breathing chamber onto its cover and remove the large worm gear clamp that holds the diaphragm in place.
7. Pull the diaphragm from the breathing chamber by its edge.
8. Use the valve core tool, supplied with the service kit, to remove the valve core from the center of the breathing chamber housing with a counterclockwise rotation. Discard the removed valve core.
9. Install a replacement valve core into the breathing chamber using the valve core tool.

WARNING: DO NOT over tighten the valve core during installation. Excessive force on the add valve may strip the threads of the valve core or the demand valve. Installation shall be made until the top of the valve is just even with the surface of the demand valve housing and the valve stem is completely above the demand housing surface.

10. Leak test the valve core installation as outlined below.
 - a) Connect the copper demand line (large diameter copper tube) to the center section demand fitting.
 - b) Install a charged oxygen cylinder into the Biopak.
 - c) Open the oxygen cylinder valve and apply Leak-Tek leak detection fluid to the valve core. Allow the Leak-Tek to remain in place for 1-minute while observing for the formation of bubbles. The formation of bubble around the valve core will indicate a leak that must be repaired through core tightening or replacement.

- d) Close the cylinder valve and allow the pressure to reduce by depressing the bypass valve.
 - e) Remove the oxygen cylinder from the Biopak and remove the demand tube connection to the center section.
11. Reinstall the diaphragm into the underside of the breathing chamber so that the vent valve button is in view. Installation of the diaphragm is best achieved by first slipping a portion of the diaphragm over the chamber edge, holding that portion in position and slowly easing the remaining portions of the diaphragm over the remainder of the chamber.
 12. Inspect the diaphragm position and verify that the edge of the diaphragm is positioned against the first shoulder of the breathing chamber wall over the entire diaphragm circumference.
 13. Secure the diaphragm into position using the large worm gear clamp.
 14. Turn the breathing chamber over and position it into the well of the lower housing making sure that the diaphragm spring is properly positioned over the vent valve.
 15. Secure the breathing chamber to the lower housing using the four anchor screws and washers.
 16. Re-install the copper plumbing connections to the breathing chamber by positioning a lightly greased o-ring seal into position and hand-tightening each connection knob. Secure the hand knobs of the connections by installing the anti-rotation collar.
 17. Reconnect the hoses to the breathing chamber and secure each with a worm gear hose clamp.
 18. Perform the Periodic Long-Term Maintenance procedures, Section V..

To Replace the Anti-Anoxia Valve Assembly, Reference the Breathing Chamber Illustrated Parts List, Section X.F.:

1. Verify that the oxygen cylinder valve is closed, rotated to its full clockwise position, and the chest-mounted pressure gauge reads zero psi.
2. Remove the upper housing, breathing chamber lid and carbon dioxide scrubber canister from the Biopak.

CAUTION: Do not use any tools to pry the breathing chamber cover or the carbon dioxide scrubber canister from the breathing chamber. Damage may occur to the o-ring seals or the components themselves. Proper removal of the cover and scrubber is made by pulling up on the edge of the component with the fingers while pushing down with the thumbs on either the breathing hose stubs or rim of the breathing chamber.

3. Use a 3/8" and a 5/16" open end wrench to disconnect the copper tubing connection from the demand valve housing to the anti-anoxia valve located in the well of the breathing chamber.
4. Loosen the mounting hardware on the valve retainer plate and slide the plate out of the breathing chamber.
5. Slide the entire valve assembly out of the breathing hose port.
6. Remove the swivel elbow fitting from the end of the valve assembly making sure to save the fitting sealing gasket.

7. Install the swivel elbow and gasket onto the replacement valve assembly and wrench tighten.
8. Position the valve assembly into the exhalation hose port of the breathing chamber.
9. Secure the valve into position using the retaining plate and mounting hardware.
10. Reconnect the copper tubing from the demand housing to the swivel elbow fitting of the valve assembly.
11. Open the oxygen cylinder to pressurize the Biopak. The plug of the valve assembly should slide out of the exhalation hose port.
12. Close the oxygen cylinder. The valve shall slide back into position within the tube stub. Replace the carbon dioxide scrubber, the breathing chamber cover and the upper housing.

I. Harness and Straps

The padded harness and oxygen cylinder strap should be replaced when tears, fraying or abrasions are evident. Reference the procedures outlined below and the Lower Housing and Top Assembly Illustrated Parts Lists, Sections X.A. and X.B. for replacement.

To Replace the Oxygen Cylinder Strap:

1. Pull up on the strap end to disengage the Velcro connection.
2. Remove the strap from the lower housing by pulling out by the metal loop end.
3. Rethread a replacement strap through the lower housing slots.

To Replace the Padded Harness:

1. Remove the upper housing.
2. Disconnect the plumbing lines and the breathing hoses to the breathing chamber.
3. Remove the breathing chamber from the lower housing.
4. Remove the chest-mounted pressure gauge from the harness while leaving it attached to the lower housing.
5. Pull the cap from each of the six harness retaining pins and remove each pin by sliding out of the harness loop.
6. Remove the harness from the Biopak.
7. Position a new replacement harness onto the lower housing and push the connection loops of the harness through the slots in the lower housing.
8. Anchor the harness into position using the six harness retainer pins and caps.

CAUTION: Do not allow tubing to become trapped between the harness pin and cap when attaching the cap to the pin.

9. Reattach the chest-mounted pressure gauge to the harness.
10. Reinstall the breathing chamber into the lower housing.
11. Reattach the breathing hoses and plumbing lines to the breathing chamber.
12. Perform the Periodic Long-Term Maintenance Procedures.
13. Reinstall the upper housing.

J. Facepiece Assembly

The check valves of the facepiece will require replacement whenever the user can not pass the positive and negative facepiece test as described in the User's Manual. The Anti-fog lens insert should be replaced whenever the insert has become scratched, torn or voids have developed in the seal around the lens perimeter. Replacement of the main facepiece lens is difficult and it is recommended that it be performed by the factory.

To Replace the Inhalation Check Valve, Reference the Facepiece Illustrated Parts Lists:

1. Remove the entire front adapter assembly from the face piece by pulling the silver retainer clip straight out away from the face piece, rotating the assembly 90° and pulling the assembly straight out of the facepiece.
2. Use a screwdriver to carefully pry the edge of the 48.5mm hose clamp up to disengage and remove the clamp from the inhalation side elbow. A green band marks the inhalation side of the assembly.
3. Pull the elbow straight off the hose connector of the assembly and retrieve the check valve, check valve holder and the hose gasket.
4. Remove the check valve from the check valve holder by pulling it through the holder. Discard the check valve.
5. Insert the tip of the new check valve through the center hole of the check valve holder and pull through the other side until the shoulder of the valve has engaged on the holder. Proper installation of the check valve will place it on the outside (or convex) side of the holder.

Caution: Do not pull the check valve completely through the center hole of the check valve holder. This may cause damage to the check valve.

6. Cut away the tip of the check valve so that the remaining tip does not extend past the edge of the check valve holder.
7. Slide the hose gasket over the check valve holder so that it is seated against the holder shoulder.
8. Position the holder and gasket into the open hose connector port of the adapter assembly.
9. Position the elbow onto the connector port of the adapter assembly and position it at the same angle as the exhalation side elbow.
10. Secure the elbow into position using a new 48.5mm hose clamp and the hose clamp-ratcheting tool, supplied as an optional tool from Biomarine.

WARNING: Do not attempt to re-use the 48.5mm hose clamp. The clamp is designed for a one-time use only. Attempts to reuse removed clamps may result in clamp disengagement during use.

11. Reinstall the adapter assembly to the facepiece by pushing it straight into the facepiece port at a 90° angle from its final position, rotating to the final position and securing by pushing in the silver retaining clip.
12. Perform the positive and negative test on the facepiece as described in the User's Manual.

To Replace the Exhalation Check Valve, Reference the Facepiece Illustrated Parts Lists:

1. Remove the entire front adapter assembly from the face piece by pulling the silver retainer clip straight out away from the face piece, rotating the assembly 90° and pulling the assembly straight out of the facepiece.
2. Use a screwdriver to carefully pry the edge of the 48.5mm hose clamp up to disengage and remove the clamp from the inhalation side elbow. A red band marks the exhalation side of the assembly.
3. Pull the elbow straight off the hose connector of the assembly and retrieve the check valve and check valve holder and the hose gasket.
4. Remove the check valve from the check valve holder by pulling it through the holder. Discard the check valve.
5. Insert the tip of the new check valve through the center hole of the check valve holder and pull through the other side until the shoulder of the valve has engaged on the holder. Proper installation of the check valve will place it on the inside (or concave) side of the holder.

Caution: Do not pull the check valve completely through the center hole of the check valve holder. This may cause damage to the check valve.

6. Cut away the tip of the check valve so that the remaining tip does not exceed ¼ in length.
7. Slide the hose gasket over the check valve holder so that it is seated against the holder shoulder.
8. Position the holder and gasket into the open hose connector port of the adapter assembly.
9. Position the elbow onto the connector port of the adapter assembly and position it at the same angle as the inhalation side elbow.
10. Secure the elbow into position using a new 48.5mm hose clamp and the hose clamp-ratcheting tool, supplied as an optional tool in the tool kit.

WARNING: Do not attempt to re-use the 48.5mm hose clamp. The clamp is designed for a one-time use only. Attempts to reuse removed clamps may result in clamp disengagement during use.

11. Reinstall the adapter assembly to the facepiece by pushing it straight into the facepiece port at a 90° angle from its final position, rotating to the final position and securing by pushing in the silver retaining clip.
12. Perform the positive and negative test on the facepiece as described in the User's Manual.

To Replace the Anti-Fog Lens Insert, Reference the Facepiece Illustrated Parts Lists:

1. Remove the existing insert from the inside surface of the facepiece lens. Discard the damaged lens.
2. Clean the inside lens of the facepiece with warm water and soap. Dry the lens completely.

WARNING: Do not use any alcohol or solvent based cleaners on the lens of the facepiece. Such cleaning fluids may cause lens crazing and damage.

3. Position a replacement lens on the inside of the facepiece. Secure the lens into position by burnishing the seal material around the perimeter of the lens with a tongue depressor. Note that replacement lenses are supplied with installation instructions.
4. Apply anti-fog to the facepiece and insert lenses as described in the Turn-Around Maintenance procedures.

To Replace the Scott-Style Wiper Blade, Reference Facepiece Wiper Assembly Illustrated Parts List, Section X.M.:

1. Remove the wiper arm from the facepiece by unthreading the #2-56 binder head screw and pulling the washer, wiper arm and wiper tension arm away from the assembly.
2. Remove the wiper blade assembly from the wiper arm by removing the #2-56 fillister head screw, #2-56 ESNA hex nut, wiper arm spacer and flex arm.
3. Position a replacement wiper blade assembly, B6-02-5001-62-0, onto the wiper arm with the flex bar, screw, spacer and nut as depicted by the illustrated drawing.
4. Reposition the tension arm onto the wiper arm and reposition the entire assembly back into the facepiece.
5. Secure the assembly into position using the #2-56 binder head screw and flat washer as depicted.
6. Thoroughly soak the wiper blade assembly and the internal facepiece lens with anti-fogging agent and allow to dry. Prior to the next use of the facepiece, lightly buff the facepiece lens and re-soak the wiper blade with the anti-fogging agent.

To Replace the AGA-Style Wiper Chamois, Reference Facepiece Wiper Assembly Illustrated Parts List, Section X.O.:

1. Pivot the wiper arm to access the self-tapping screw.
2. Remove the self-tapping screw from one end of the assembly to disengage the flexible cable of the wiper.
3. Cut the nylon lacing away and slide the chamois off the flexible cable.
4. Slide a new chamois, B2-02-7100-13-0, over the flexible cable and secure into position by tying with the nylon lacing supplied.
5. Reattach the free end of the flexible cable to the pivot arm using the self-tapping screw.

K. Factory Service and Training

In the event Biopak problems arise that can not be corrected or repaired through the procedures provided in the Benchman Training Manual, factory service may be obtained by contacting the manufacturer as direct below.

Additionally, the manufacturer offers training programs for Biopak Benchmen and Users. Training sessions will provide a complete review of all procedures provided in the Benchman Training Manual as well as use training.

The factory can be contacted as followed:

By Mail: ***Biomarine Incorporated***
ATTN: Service Department
456 Creamery Way
Exton, PA 19341-2532 USA

By Phone: (610) 524-8800, Monday through Friday, 9AM through 4PM

By FAX: (610) 524-8807

By EMAIL: NeutronicsInc.com

All service correspondence to the factory should include the below listed information:

- Biopak Model Number
- Biopak Serial Number
- Date of Biopak Purchase
- Approximate Number of Biopak Uses
- Description of Biopak Problem
- Actions Taken to Correct Problem
- Contact Name, Address and Phone Number

VII. Troubleshooting Guide

The following is provided as a guide for the Benchman to troubleshoot the Biopak. Problems or issues that arise that can not be corrected by the Benchman with assistance from this manual should be referred to the factory.

Problem: Mask fogging during use.

Probable Causes:

1. Anti-Fog lens insert not installed or damaged.
2. Anti-Fog agent not applied or applied incorrectly.

Remedy:

1. Install or replace the Anti-Fog lens according to procedures set forth in Section VI.H.
 2. Reapply the Anti-Fog agent according to procedures set forth in Section IV.H.
-
-

Problem: Not achieving full sixty-minute duration of Biopak during use.

Probable Causes:

1. Poor or leaking facepiece seal.
2. Oxygen cylinder opened prior to donning facepiece.
3. Bypass valve utilized to clear facepiece lens or used excessively.
4. User under heavy work loads or extreme ambient conditions.
5. Leak in Biopak.
6. Pressure Regulator Failure.

Remedy:

1. Readjust the facepiece. User should train for proper facepiece seal using the Facepiece Fit Test of Section V.E.. The facepiece seal will be difficult, if not impossible, to achieve if the user has any facial hair or is wearing glasses that interfere with proper facepiece fit. The user should be clean shaven and should utilize optional spectacle mounting kits if glasses are worn.
2. Do not open the oxygen cylinder valve until after the facepiece has been donned. If the oxygen cylinder valve is opened prior to donning the facepiece excessive loss of the oxygen stores will result.
3. Use of the bypass valve in an attempt to clear the facepiece will result in excessive loss of oxygen stores and will not aid in clearing the lens. The bypass valve should only be utilized in emergency situations since it will dump unrestricted flow directly into the breathing loop and will not conserve the oxygen stores.
4. Whenever the user is under heavy workloads or placed into a hot environment, the body will require a higher than usual intake of oxygen. Such situations may serve to shorten the duration of the Biopak below the sixty-minute rating.
5. Leaks in the breathing loop, the low-pressure system and the high-pressure system will serve to shorten Biopak duration. Inspect the Biopak systems to the procedures of the Periodic Long-Term Maintenance, Section V.
6. In the rare event of pressure regulator failure, the user should following the emergency procedures described in the User's Manual and immediately evacuate the area. Replace the pressure regulator according to the procedure set forth in Section VI.D. of this manual. Note that regulator failure can be diagnosed by a failure of the flow test with flows over 2.4 lpm.

Problem: High breathing resistance during exhalation.

Probable Causes:

1. Facepiece exhalation valve sticking closed.
2. Diaphragm spring in breathing chamber is not properly seated or damaged.
3. Vent valve in breathing chamber not opening properly.
4. Anti-Anoxia valve in breathing chamber is not opening properly.
5. Test key left in place after testing.

Remedy:

1. Remove the check valve, inspect, clean and replace if required according to the procedures set forth in Section VI.J..
2. Follow the procedures of Section VI.H. to remove the breathing chamber from the Biopak. Inspect the position of the diaphragm spring and verify that the free end of the spring is positioned over and around the diaphragm vent valve assembly. Replace the spring if it appears damaged.
3. Remove, clean, inspect and replace worn or damaged components in the vent valve according to procedures set forth in Section VI.H.. Note that excessive lubrication on the primary and secondary vent seat o-ring seals may cause valve sticking.
4. Follow the procedures of Section VI.H. to replace the anti-anoxia valve. Before replacing the valve verify that no foreign particles have become jammed between the valve plug and the breathing hose port causing the valve to stick.
5. Remove test key.

Problem: High breathing resistance during inhalation.

Probable Causes:

1. Facepiece inhalation check valve sticking closed.
2. Diaphragm spring in breathing chamber is missing or damaged.
3. Demand valve in breathing chamber has failed.
4. Anti-Anoxia valve in breathing chamber is not operating properly.

Remedy:

1. Remove the check valve, inspect, clean and replace if required according to the procedures set forth in Section VI.J..
2. Follow the procedures of Section VI.H. to remove the breathing chamber from the Biopak. Replace the spring if it appears damaged or install the spring if it is missing.
3. Replace the valve core in the breathing chamber according to the procedures in Section VI.H.
4. Follow the procedures of Section VI.H. to replace the anti-anoxia valve. Before replacing the valve verify that no foreign particles have become jammed between the valve plug and the breathing hose port causing the valve to stick.

Problem: Alarm indications of remaining service time not functioning correctly.

Probable Causes:

1. Chest mounted pressure gauge has failed or pressure line has been severed.
2. Alarm whistle requires tone adjustment.
3. Alarm whistle has failed.

Remedy:

1. Replace the chest-mounted pressure gauge referencing the parts lists of Section X.A.
2. Adjust the tone of the alarm whistle according to the procedure set forth in Section VI.F..
3. Replace the alarm whistle assembly according to the procedure set forth in Section VI.F..

Problem: Sounds of escaping gas heard during use.

Probable Causes:

1. Poor facepiece fit is causing breathing loop leak. Sound of escaping gas is being made by constant oxygen adds into the breathing loop by the demand valve.
2. Sealing washer between the oxygen cylinder and the pressure regulator is missing or damaged resulting leakage of high-pressure oxygen from the cylinder.
3. Biopak has a leak in the breathing loop or the high or low pressure plumbing systems.

Remedy:

1. Readjust the facepiece. User should train for proper facepiece seal using the Facepiece Fit Test of Section V.E.. The facepiece seal will be difficult, if not impossible, to achieve if the user has any facial hair or is wearing glasses that interfere with proper facepiece fit. The user should be clean shaven and should utilize optional spectacle mounting kits if glasses are worn.
2. Replace or install the sealing washer onto the center stem of the pressure regulator.
3. Perform the Periodic Long-Term low and high-pressure leak testing of Sections V.B. and V.C..

Problem: Breathing gas is uncomfortably warm during use.

Probable Causes:

1. User is unfamiliar with conditions of Biopak supplied atmospheres.
2. Cooling rings have not regenerated.
3. User is working in high ambient temperatures.

Remedy:

1. The Biopak will supply breathing gas to the user at temperatures below 105°F throughout the sixty-minute duration. Breathing gas temperatures will be cool at the start of Biopak use and will continually rise as the user work load increases and as the coolant insert begins to melt.
2. Verify that the Biopak was not stored in excessive temperatures (in excess of 85°F) prior to its use. Storage of the Biopak in excessive temperature may result in the melting and prevention of cooling ring crystal regeneration.
3. Should the user be exposed to high ambient temperatures, the temperature of the supplied breathing may rise above 90°F. For cases of high ambient temperature it may be necessary to utilize a secondary cooling device in order to provide comfortable temperatures.

Problem: Facepiece fails positive and/or negative testing during user donning.

Probable Causes:

1. Inhalation or exhalation check valve failure in the facepiece.

Remedy:

1. Follow the check valve replacement procedures for the inhalation and/or exhalation check valves as set forth in Section VI.J..
-
-

Problem: Biopak fails leak testing.

Probable Causes:

1. Component connections loose.
2. System leak.

Remedy:

1. Inspect the connections of components such as the coolant canister end cap, breathing hose ends, connection hose ends and breathing chamber plumbing connections to verify that they are properly made and tight.
 2. Leak test the system using Leak-Tec inspection fluid as described in the Periodic Long-Term Maintenance procedures, Section V..
-
-

Problem: Biopak fails flow test.

Probable Causes:

1. Flow restrictor in breathing chamber has clogged.
2. Demand valve of breathing chamber has failed.
3. Pressure regulator has failed.

Remedy:

1. Replace the flow restrictor according to the procedure of Section VI.G..
2. Replace the demand valve core according to the procedures of Section VI.H..
3. Replace the pressure regulator according to the procedure of Section VI.D..

VIII. Biopak Specifications

Rebreather Type:	Self-Contained, Closed Circuit
Rebreather Duration: device	NIOSH rated for 60-minutes as an entry and escape device
Protection:	Positive Pressure
Protection Factor (PF):	greater than 20,000
Size:	18.5 x 13.8 x 6.6 inches (470 x 351 x 168 millimeters)
Weight-Fully Charged:	25 pounds (11.4 kilograms) Including Facepiece, Hoses, Coolant, Oxygen and Carbon Dioxide Absorbent
End of Service Alarms:	92dB, 5mHz whistle sounding for 45-60 seconds to indicate 25% of rated duration (approximately 15-minutes) remaining. Red visual indication on chest mounted pressure gauge to indicate 25% of rated duration (approximately 15-minutes) remaining.
Oxygen Cylinder:	DOT Approved Pressure Vessel Supplied with Pressure Gauge and Valve 6.77 cubic feet at 2250 psig fill (192 liters at 159 kg/cm ² fill)
Operation Temperature Range:	-15 to 130°F (-26 to 54°C)
Storage Temperature Range:	32 to 85°F (0 to 30°C)
Materials of Construction:	
Housing Shells:	High impact, fire retardant Makrolon ^R #6455
Breathing Hoses:	Neoprene with optional Nomex ^R covering
Facepiece:	Silicone rubber, polycarbonate lens, ABS
Plumbing:	Copper, brass
Breathing Chamber:	Polypropylene housing Stainless steel cover Neoprene diaphragm ABS/Delrin components
Approval:	NIOSH/MSHA approved as entry into and escape from oxygen deficient atmospheres breathing apparatus Approval Numbers TC-13F-371 and TC-13F-372 Reference Approval Label on Page 4

IX. Warranty Statement

Biomarine warrants, subject to the terms below, that the goods will be free from defects in design, materials, and workmanship for a period of three (3) years from the date that the goods are purchased by buyer, with the exception of rubber components. Rubber and silicone rubber components are similarly warranted for a period of one (1) year from the date of purchase. THIS WARRANTY DOES NOT APPLY TO OXYGEN CYLINDER HYDROSTATIC TESTING FOR PERIODIC RECERTIFICATION OF THE PRESSURE VESSEL.

THE SOLE LIABILITY OF BIOMARINE FOR ALL PURPOSES SHALL BE TO REPLACE, AT THE SOLE OPTION OF BIOMARINE, DEFECTIVE PARTS APPEARING WITHIN THE THREE OR ONE-YEAR PERIOD AS APPLICABLE. BIOMARINE SHALL PROVIDE PARTS AT ITS OWN EXPENSE BUT ALL LABOR SHALL BE AT THE EXPENSE OF THE BUYER. BIOMARINE SHALL HAVE NO OBLIGATION FOR REPLACEMENT UNLESS:

1. BIOMARINE HAS RECEIVED WRITTEN NOTICE OF THE ALLEGED DEFECT WITHIN THIRTY (30) DAYS FOLLOWING THE DISCOVERY OF THE DEFECT OR THIRTEEN (13) MONTHS FROM THE DATE OF PURCHASE, WHICHEVER OCCURS SOONER; AND
2. THE BUYER SUBMITS PROOF OF DATE OF PURCHASE WITH INVOICE OR EQUIVALENT DOCUMENTATION; AND
3. THE DEFECTIVE GOODS ARE PROMPTLY RETURNED BY BUYER, AT THEIR SOLE EXPENSE TO BIOMARINE AT: 456 CREAMERY WAY, EXTON, PA 19341 USA; AND
4. THE EQUIPMENT HAS NOT BEEN ALTERED; AND
5. THE DEFECT OCCURS UNDER CIRCUMSTANCES OF PROPER USE IN ACCORDANCE WITH ALL INSTRUCTIONS AND MANUALS PROVIDED TO THE BUYER.

It shall be the responsibility of the buyer to read carefully and abide by all instructions provided to the buyer in the instruction manual or elsewhere. If buyer, and the employees of the buyer, did not abide by such instructions, then the alleged defect shall not be deemed to have arisen under circumstances of proper use. The instructions for use of the goods reflect the opinion of experts based on field use and tests. The instructions should be followed carefully. It is impossible, however, to eliminate all risks inherently associated with the use of the goods. Unintended consequences may result because of factors as weather conditions, the presence of other materials, or the use or manner of application of the goods, all of which are beyond the control of Biomarine. All such risks shall be assumed by the buyer.

Buyer shall be responsible for insuring that the goods are functioning properly at all times and shall not use any goods which are not functioning properly. If buyer uses goods when they are not functioning properly, then buyer agrees to defend, indemnify and hold Biomarine harmless against all losses, damages and injuries to persons or property as a result of the use of the malfunctioning goods.

These warranties do not extend to the goods if they have been subjected to misuse, neglect or accident, including extended exposure to direct flames and/or caustic chemical products, after its delivery to buyer, nor does it extend to any item that was modified or altered after its delivery to buyer.

IN NO EVENT WILL BIOMARINE BE LIABLE FOR ANY LOSS OR DAMAGE DIRECTLY OR INDIRECTLY ARISING FROM THE DEFECTS OR FROM THE USE OF THE GOODS OR FOR CONSEQUENTIAL OR INCIDENTAL DAMAGES, WHETHER IN CONTRACT, TORT, OR OTHERWISE, OR FOR PERSONAL INJURY OR PROPERTY DAMAGE OR ANY FINANCIAL LOSS.

Any description of the goods contained in any documents to which these warranty provisions related, including any quotations or purchase orders relating to the goods being delivered to buyer, are for the sole purpose of identifying the goods, and any such description, as well as any sample or model which may have been displayed to or seen by buyer at any time, have not been

made part of the basis of the bargain and have not created or amounted to any warranty, express or implied, that the goods would conform to any such description or any such sample or model.

EXCEPT AS SPECIFICALLY SET FORTH IN THESE WARRANTIES, BIOMARINE MAKES NO WARRANTIES, EXPRESS OR IMPLIED, WHETHER ARISING BY LAW, CUSTOM, CONDUCT OR USAGE OF TRADE, INCLUDING WARRANTIES AS TO MERCHANTABILITY, OR AS TO THE FITNESS OF THE GOODS FOR ANY PARTICULAR USE OR PURPOSE, AND ANY WARRANTIES INCLUDING WARRANTIES AS TO MERCHANTABILITY AND FITNESS FOR PARTICULAR USE OR PURPOSE AND THE RIGHTS AND REMEDIES PROVIDED HEREIN ARE EXCLUSIVE. THESE WARRANTIES SHALL RUN TO THE BUYER ONLY AND SHALL NOT BE CONSTRUED AS A CONDITION.

Biomarine does not warrant that the goods are free from the rightful claim of any third person by way of infringement or patents or other proprietary information or disclaims any warranty against such infringement.

The terms of these warranties shall apply to the product sold by Biomarine, except absorbent, filters and anti-fog lens inserts which are considered "consumable item", and as such are not covered by the terms of these warranties. No waiver, alteration or modification of the terms of these provisions shall be valid unless in writing and signed by an executive officer of Biomarine.

These warranties shall not apply to accessories or devices purchased by Biomarine and attached to or made part of the goods except that Biomarine warrants the (i) the installation of such items in the completed product shall so conform to the installation instructions of the manufacturers thereof as not to invalidate such applicable warranties on such items as are obtained by Biomarine from such manufacturers, and (ii) the workmanship incorporated in such installation shall be free from defects.

X. Illustrated Parts Lists

A. Top Assembly

ITEM#	QTY	PART NUMBER	DESCRIPTION
REF	-	B7-07-0900-00-0	Standard Biopak 60TE Complete Rebreather
REF	-	B7-07-0900-02-0	Japanese Biopak 60TE Complete Rebreather
REF	-	B7-07-0900-03-0	Standard Biopak 60TE Complete Rebreather with Nomex Hoses and Kevlar Harness
1	1		Upper Housing Assembly-Reference page 46
2	1		Lower Housing Assembly-Reference page 45
3	1		Pneumatic Assembly-Reference page 47
4	1		Breathing Chamber Assembly-Reference page 49
5A	1	B2-05-1000-02-0	Standard Chest Mounted Pressure Gauge
5B	ALT	B2-05-1000-05-0	Metric Chest Mounted Pressure Gauge
6A	1	B6-02-5000-12-1	Standard Oxygen Cylinder-Reference page 55
6B	ALT	B6-02-5000-69-1	Japanese Oxygen Cylinder-Reference page 55
7	1		Carbon Dioxide Scrubber-Reference page 52
8	1		Breathing Chamber Cover-Reference page 54
9A	1	B6-02-5000-76-0	Neoprene Exhalation Breathing Hose-Reference page 53
9B	ALT	B6-02-5000-76-1	Nomex Exhalation Breathing Hose-Reference page 53
10A	1	B6-02-5000-78-0	Neoprene Inhalation Breathing Hose-Reference page 53
10B	ALT	B6-02-5000-78-1	Nomex Inhalation Breathing Hose-Reference page 53
11	1	B2-02-0000-15-0	Alarm Whistle Mounting Clamp
12	1	B2-06-6000-68-0	Chest Mounted Pressure Gauge Line Clamp
13	2	B2-06-6000-01-0	Breathing Hose Clamp
14	1	B2-02-0000-19-0	Chest Gauge Flow Restrictor Fitting
15	1	B2-02-1300-11-0	Breathing Hose Coupler Fitting
16	1	B3-02-4060-00-0	#6-32 ESNA Hex Nut
17	1	B3-01-1061-02-0	#6-32 x 1/2" Pan Head Screw
18	3	B3-01-1061-03-0	#6-32 x 7/16" Pan Head Screw
19	1	B3-01-1081-01-0	#10-32 x 3/8" Pan Head Screw
20	4	B3-01-1081-00-0	#10-32 x 1" Pan Head Screw
21	1	B3-03-2083-00-0	#10 Lock Washer
22	4	B3-03-1083-00-0	#10 Flat Washer
23	1	B3-03-0006-00-0	Bypass Valve Mounting Washer
24	1	B5-06-6900-02-0	User Instruction Manual
25	1	B5-06-6900-06-0	Benchman Manual
26	1	B2-02-7000-39-0	Biopak SoftPak Carrying Case
27	OPT	B6-02-5000-89-0	Biopak 60TE Service Kit-Reference page 61

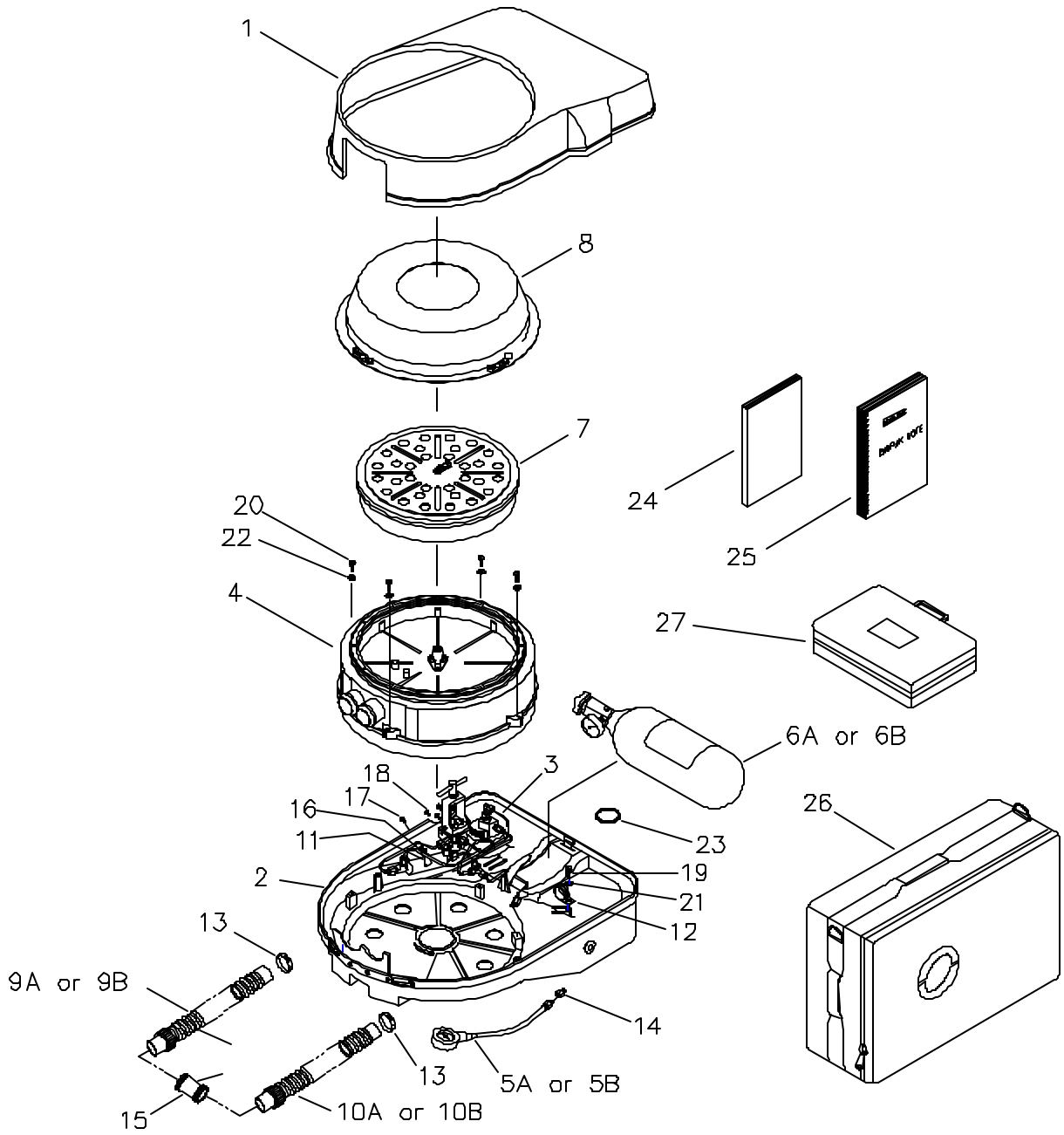

B. Lower Housing Assembly

ITEM#	QTY	PART NUMBER	DESCRIPTION
REF	-		Biopak 60TE Lower Housing Assembly
1	1	B6-02-5000-73-0	Lower Housing Shell with Riveted Parts
2	1	B2-02-7000-47-0	Hose Skirt
3	2	B2-02-3300-33-0	Upper Housing Keeper Bracket
4	2	B2-02-1300-02-0	Breathing Chamber Vertical Mount
5	2	B2-02-1300-14-0	Breathing Chamber Angled Mount
6	1	B2-06-6000-78-0	Oxygen Cylinder Hold-Down Strap
7	1	B3-04-0300-02-0	Chest Gauge Hose Grommet
8	1	B2-02-3300-02-0	Diaphragm Spring
9	2	B2-02-3300-01-0	Diaphragm Spring Retention Clip
10	8	B3-01-1042-00-1	#4-40 x 3/8" Pan Head Screw
11	8	B3-01-1061-03-0	#6-32 x 7/16" Pan Head Screw
12	2	B3-03-1043-01-0	#4 Flat Washer
13	9	B3-03-1063-00-0	#6 Flat Washer
14	8	B3-02-0040-00-0	#4-40 ESNA Hex Nut
15	1	B3-02-4060-00-0	#6-32 ESNA Hex Nut
16	1	B3-01-1061-01-0	#6-32 x 3/8" Pan Head Screw
17	1	B2-06-6000-12-0	Chest Gauge Harness Mounting Clip
18A	1	B2-02-0000-33-0	Nylon Harness Assembly
18B	ALT	B2-02-7000-95-0	Kevlar Harness Assembly
19	2	B2-02-4100-20-0	Short Harness Retention Pin
20	4	B2-02-4100-21-0	Long Harness Retention Pin
21	6	B2-02-4100-22-0	Harness Retention Pin Cap

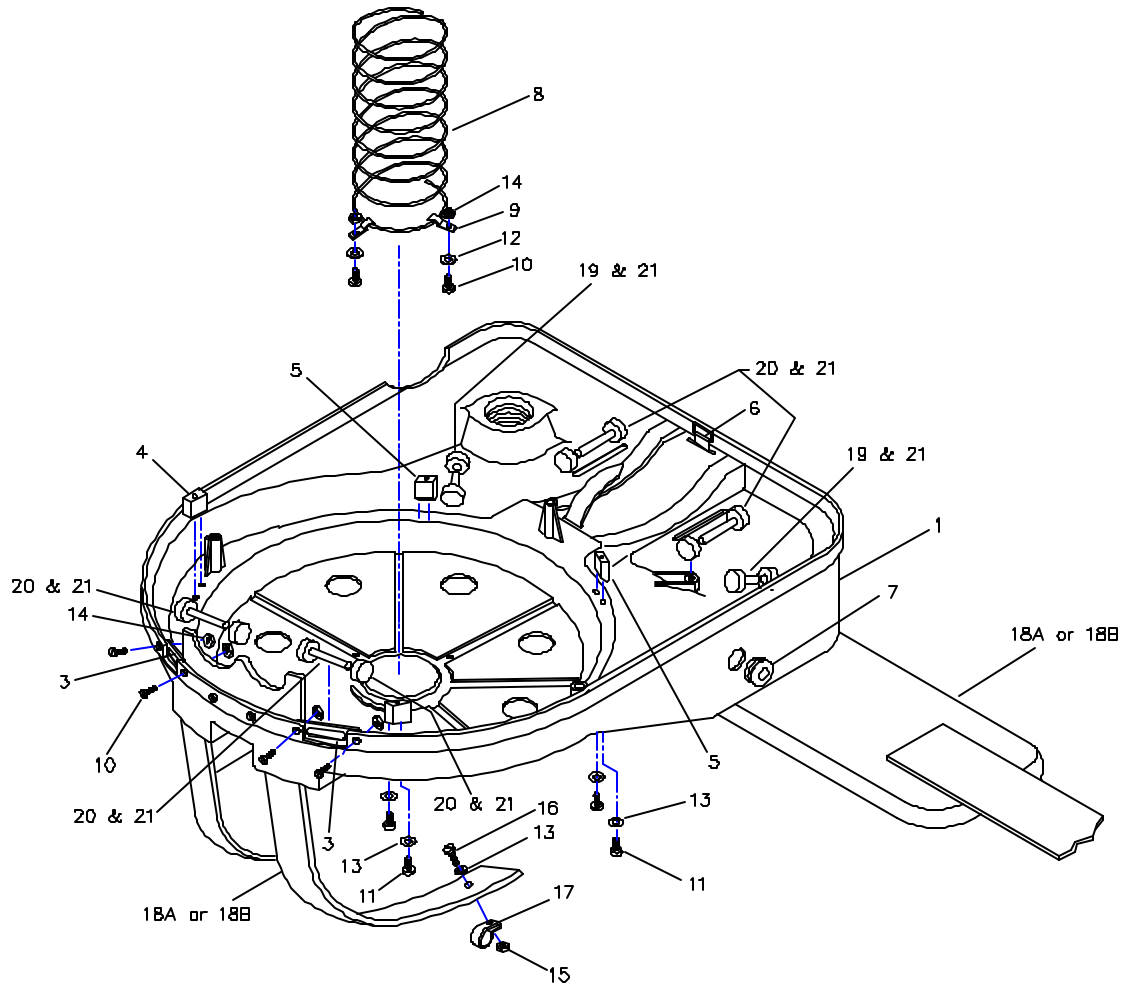

C. Upper Housing Assembly

ITEM#	QTY	PART NUMBER	DESCRIPTION
REF	-	B6-02-5000-72-0	Biopak 60TE Upper Housing Assembly
1	1	B6-02-5000-72-1	Upper Housing Shell with Labels and Latch
2	1	B2-02-1000-01-0	Caution Label
3	1	B2-02-7000-10-0	Warning Label
4	1	B2-06-6001-02-0	Flexible Draw Latch
5	2	B2-02-1100-02-0	Latch Plate
6	4	B3-01-1021-03-0	#2-56 x 1/4" Pan Head Screw
7	4	B3-03-3023-00-0	#2 Internal Tooth Washer
8	2	B3-03-1043-01-0	#4 Flat Washer
9	2	B3-05-2000-02-0	Rivet

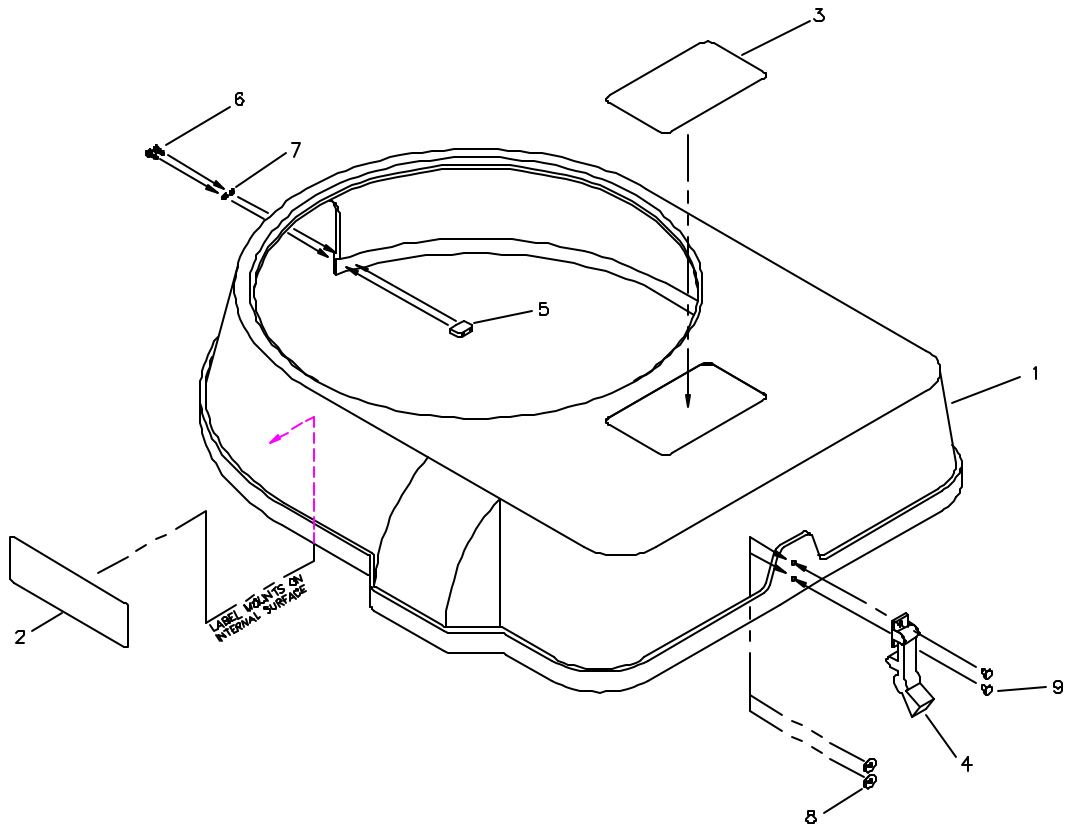

D. Pneumatic Assembly

ITEM#	QTY	PART NUMBER	DESCRIPTION
REF	1		Biopak 60TE Pneumatic Assembly
1	1	B6-02-5000-47-0	Alarm Whistle Assembly
2	1	B6-02-5000-56-0	Bypass Valve Assembly -Reference page 48
3	1	B6-02-5000-77-0	Regulator Assembly-Includes Bracket, Yoke, Yoke Screw, Regulator and Fittings
4	1	B3-03-0006-01-0	Oxygen Cylinder Sealing Washer
5	1	B2-02-7100-05-0	Anti-Rotation Collar
6	1	B2-02-5000-12-0	Demand/Free Flow Tube
7	1	B2-02-5000-13-0	Low Pressure Alarm Tube
8	1	B2-02-5000-10-0	High Pressure Supply Tube
9	1	B2-02-5000-11-0	High Pressure Alarm Tube
10	1	B2-02-5000-09-0	Chest Gauge Supply Tube
11	1	B2-02-5000-08-0	Bypass Supply Tube
12	1	B2-02-5000-14-0	Bypass Tube
13	1	B4-03-5202-00-0	1/8" Tube Union Tee Fitting
14	1	B3-03-1103-00-0	3/8" Flat Washer

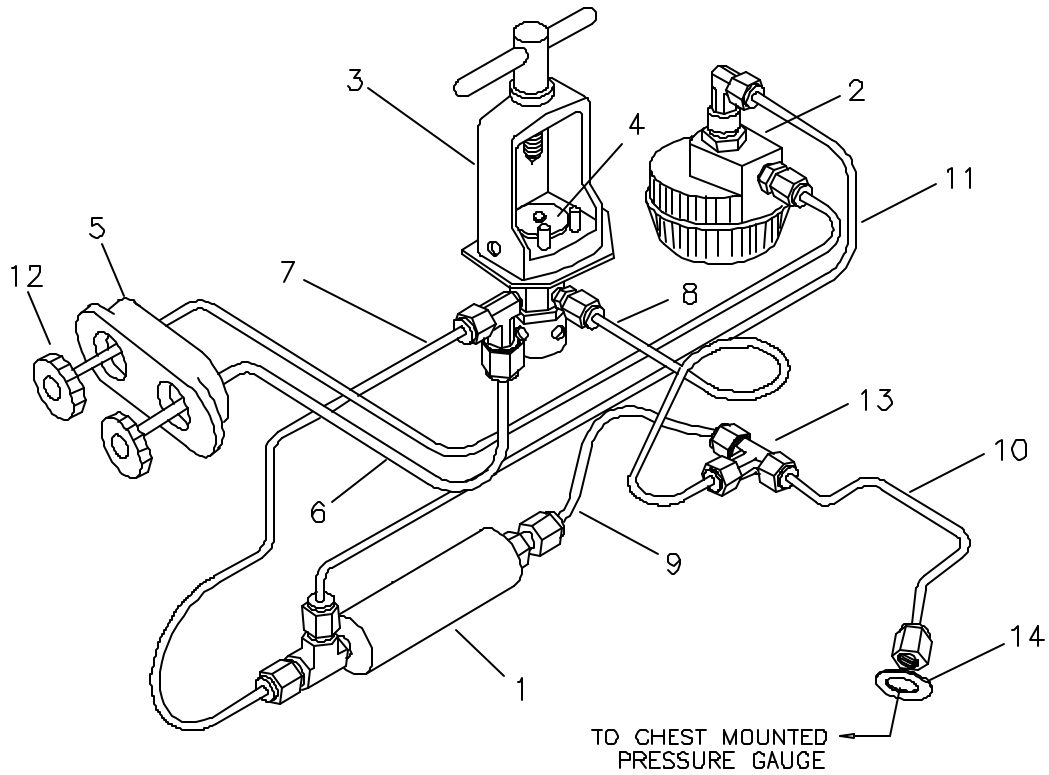

E. Bypass Valve Assembly

ITEM#	QTY	PART NUMBER	DESCRIPTION
REF	-	B6-02-5000-56-0	Bypass Valve Assembly
1	1	B2-02-4100-19-0	Valve Body
2	1	B2-02-0000-12-0	Valve Button
3	1	B2-02-4100-18-0	Valve Guard
4	1	B2-06-6000-13-0	Valve Spring
5	1	B4-04-0000-00-0	Valve Core
6	1	B4-03-5204-02-0	1/8" Tube Male Connector Fitting
7	2	B4-04-7070-03-0	O-Ring Seal, 0.367 OD x 0.239 ID
8	1	B4-04-7070-07-0	O-Ring Seal, 0.245 OD x 0.114 ID
9	1	B2-02-5400-01-0	Valve Holder
10	1	B4-03-5203-00-0	1/8" Tube Female Elbow Fitting

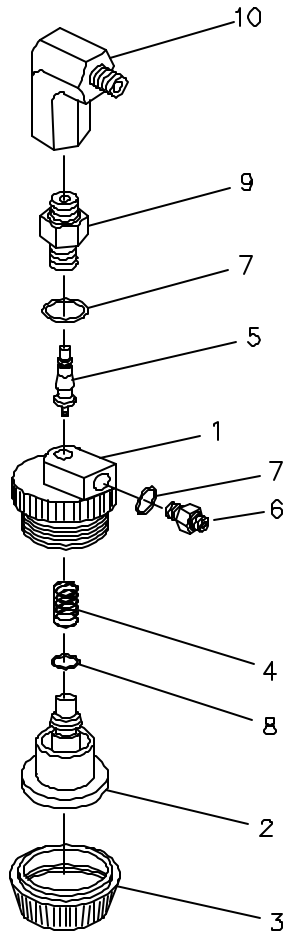

F. Breathing Chamber Assembly

ITEM#	QTY	PART NUMBER	DESCRIPTION
REF	-		Biopak 60TE Breathing Chamber Assembly
1	1	B2-02-0000-31-0	Center Section Housing
2	1	B6-02-5000-36-0	Diaphragm Assembly-Reference page 51
3	1	B2-06-6000-19-0	Diaphragm Worm Gear Clamp
4	AR	B5-02-6000-01-0	Hose Port Tape-Red
5	AR	B5-02-6000-02-0	Hose Port Tape-Green
6	2	B2-02-4100-10-0	Hose Port Ring
7	AR	B5-01-3000-05-0	Eastman 910 Adhesive
*8	1	B2-02-3300-05-0	Demand Tube Male Connector
*9	1	B2-02-3300-06-0	Bypass Tube Male Connector
10	1	B2-02-5100-02-0	Demand Valve Housing
11	1	B2-02-0000-16-0	Demand Housing Flow Restrictor
12	1	B4-04-0000-00-0	Demand Housing Valve Core
13	1	B2-02-3300-04-0	Demand Housing Supply Tube
14	1	B2-02-7100-03-0	Demand Housing Gasket
15	1	B6-02-5000-49-1	Anti-Anoxia Valve Assembly
16	1	B2-02-5000-15-1	Anti-Anoxia Valve Supply Tube
17	1	B2-02-3300-18-0	Anti-Anoxia Valve Mounting Bracket
18	1	B4-03-5003-00-0	#10-32 Swivel Elbow Fitting
19	1	B4-03-5204-04-0	#10-32 x 1/8" Tube Male Connector Fitting
20	4	B2-06-6000-02-0	Latch Stud
21	3	B3-01-0043-00-0	#4-40 x 3/8" Flat Head Screw with O-Ring
22	2	B3-01-1061-02-0	#6-32 x 1/2 Pan Head Screw
23	2	B3-03-1063-00-0	#6 Flat Washer
24	3	B3-02-0040-00-0	#4-40 ESNA Hex Nut
25	2	B3-02-4060-00-0	#6-32 ESNA Hex Nut
26	1	B2-06-6000-09-0	#10 Sealing Gasket
27	1	B4-04-7060-02-0	O-Ring Seal, 10.145 OD x 9.725 ID
28	1	B4-04-7060-03-0	O-Ring Seal, 10.895 OD x 10.475 ID
29	2	B4-04-7070-07-0	O-Ring Seal, 0.245 OD x 0.114 ID
30	1	B4-04-7070-01-0	O-Ring Seal, 0.423 OD x 0.351 ID
31	1	B4-04-7070-03-0	O-Ring Seal, 0.367 OD x 0.239 ID
32	1	B4-04-7060-01-0	O-Ring Seal, 0.505 OD x 0.299 ID
33	1	B4-04-7070-02-0	O-Ring Seal, 0.316 OD x 0.176 ID
34	1	B4-04-7070-00-0	O-Ring Seal, 0.441 OD x 0.301 ID

* Indicated Fittings require 25-30 in-lbs of torque when installed into center section.

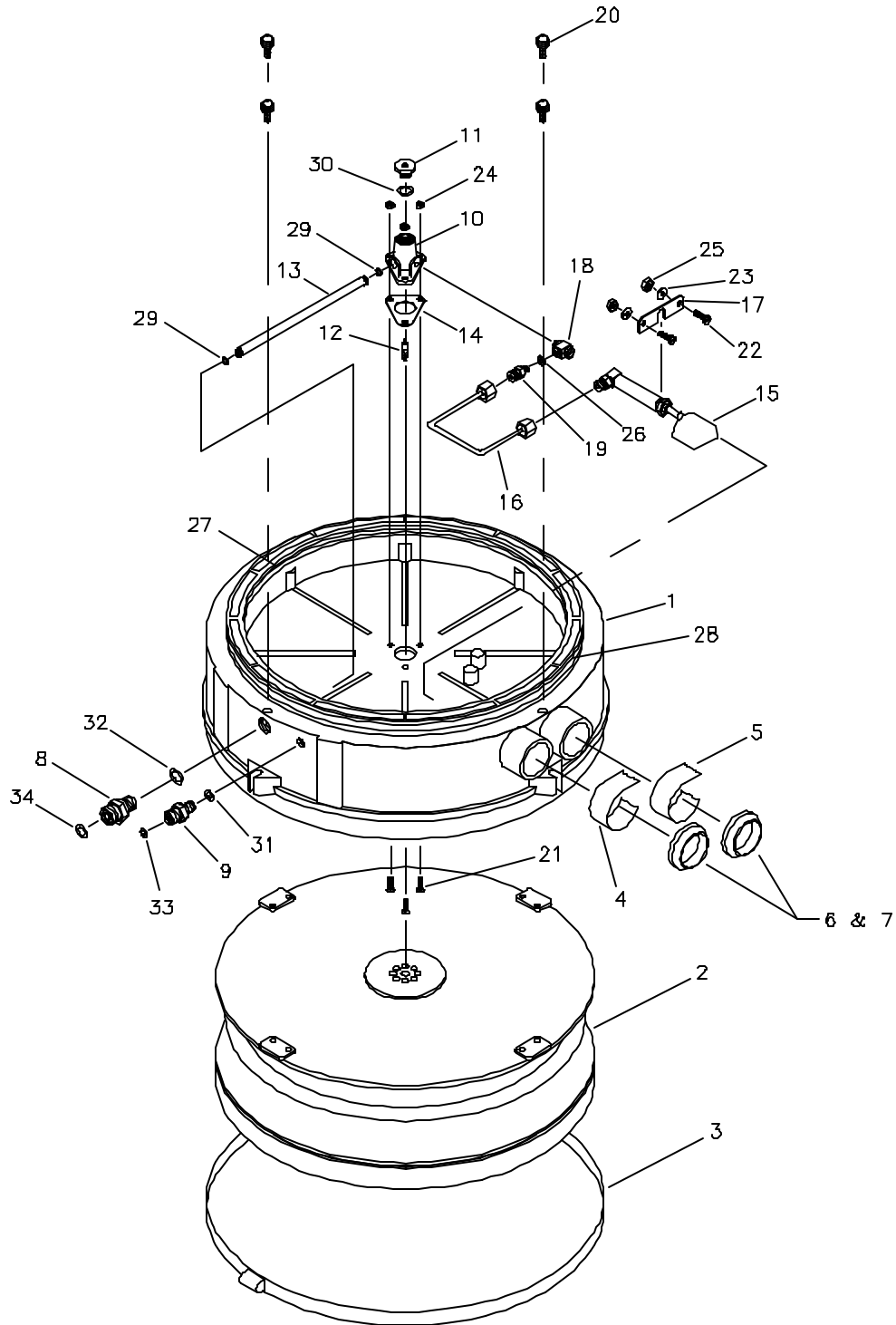

G. Diaphragm Assembly

ITEM#	QTY	PART NUMBER	DESCRIPTION
REF	-		Biopak 60TE Diaphragm Assembly
1	1	B6-02-5000-41-0	Diaphragm with Hardware
2	1	B6-02-5000-34-0	Vent Valve Cap with Screen
3	1	B2-02-4100-03-0	Vent Valve Primary Body
4	1	B2-02-4100-04-0	Vent Valve Secondary Body
5	1	B2-02-4100-05-0	Vent Valve Primary Seat
6	1	B2-02-4100-06-0	Vent Valve Secondary Seat
7	1	B2-06-6000-20-0	Vent Valve Spring-Silver
8	2	B4-04-7060-05-0	O-Ring Seal, 2.193 OD x 1.987 ID
9	2	B4-04-7060-04-0	O-Ring Seal, 1.005 OD x 0.799 ID
10	1	B2-02-3300-14-0	Vent Valve Spring-Red

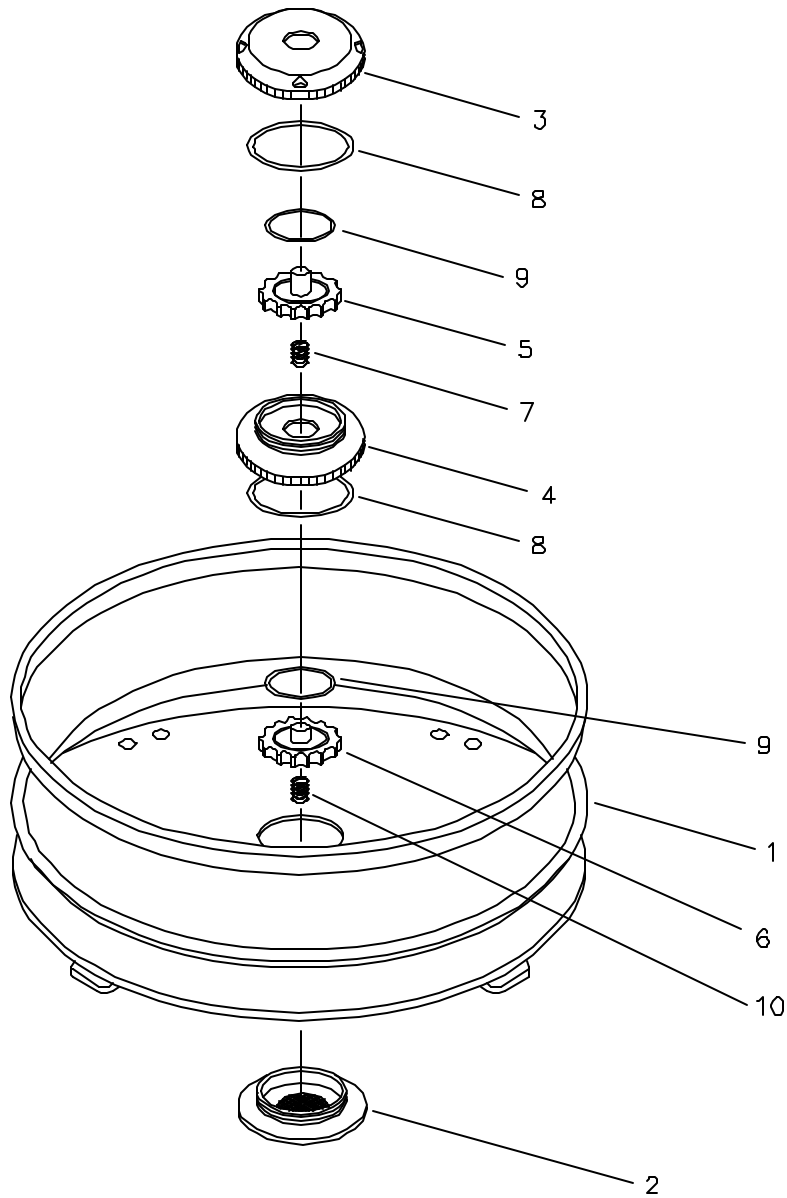

H. Carbon Dioxide Scrubber Assembly

ITEM#	QTY	PART NUMBER	DESCRIPTION
REF	-		Biopak 60TE Carbon Dioxide Scrubber Assembly
1	1	B2-02-4100-00-0	Scrubber Housing
2	1	B6-02-5000-33-0	Scrubber Cover
3	1	B2-02-7100-11-0	Scrubber Filter Disc
4	1	B2-02-7100-10-0	Scrubber Foam Pad
5	1	B2-06-6000-02-0	Latch Stud
6	1	B3-03-2083-00-0	#10 Flat Washer
7	1	B3-02-1080-00-0	#10-32 Hex Nut
*8	AR	B5-01-3000-00-0	Soda-Sorb
9	OPT	B2-02-3100-11-0	Scrubber Cover Latch Lock

* B5-01-3000-00-0 will supply twelve (12) single-use bags of Soda-Sorb and twelve (12) Turn-Around Maintenance Tags.

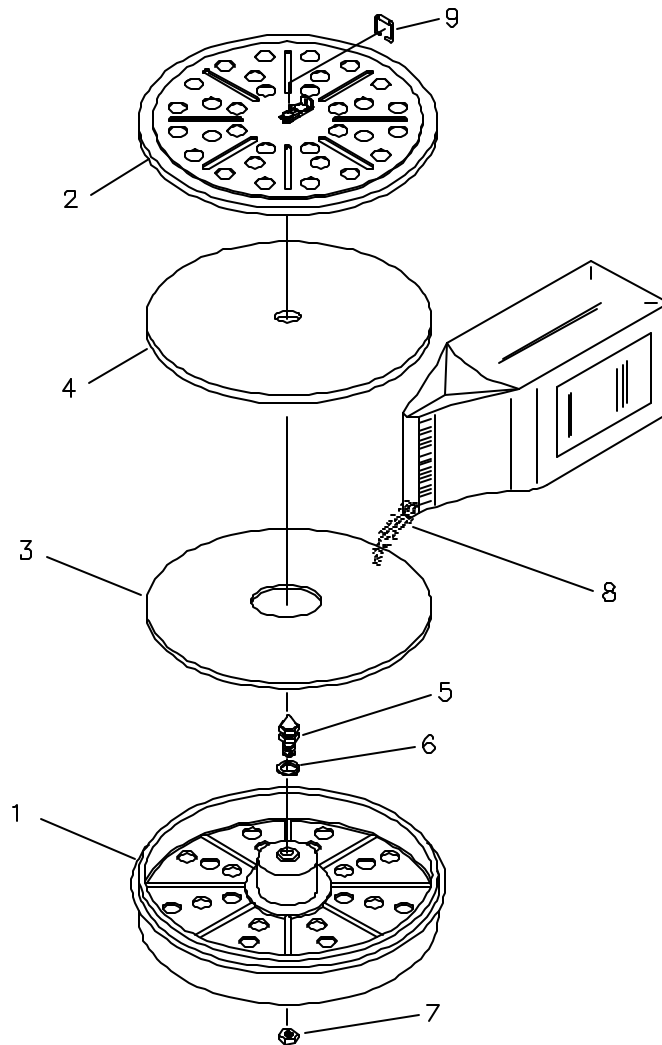

I. Breathing Hose Assemblies

ITEM#	QTY	PART NUMBER	DESCRIPTION
REF	-	B6-02-5000-78-0	Neoprene Inhalation Hose Assembly
1	1	B2-02-7100-01-0	Hose Connector Gasket
2	1	B2-02-1300-01-0	Hose Connector Body
3	1	B2-02-1300-00-0	Hose Connector Nut
4	1	B2-06-6000-07-0	31.6mm Hose Clamp
5	1	B2-02-7000-12-0	Neoprene Breathing Hose
6	2	B3-04-0300-06-0	8": Cable Tie-Green
7	1	B2-02-7000-90-0	Neoprene Inhalation Hose ID Label

ITEM#	QTY	PART NUMBER	DESCRIPTION
REF	-	B6-02-5000-76-0	Neoprene Exhalation Hose Assembly
1	1	B2-02-7100-01-0	Hose Connector Gasket
2	1	B2-02-1300-01-0	Hose Connector Body
3	1	B2-02-1300-00-0	Hose Connector Nut
4	1	B2-06-6000-07-0	31.6mm Hose Clamp
5	1	B2-02-7000-12-0	Neoprene Breathing Hose
6	2	B3-04-0300-05-0	8": Cable Tie-Red
7	1	B2-02-7000-91-0	Neoprene Exhalation Hose ID Label

ITEM#	QTY	PART NUMBER	DESCRIPTION
REF	-	B6-02-5000-78-1	Nomex Inhalation Hose Assembly
1	1	B2-02-7100-01-0	Hose Connector Gasket
2	1	B2-02-1300-01-0	Hose Connector Body
3	1	B2-02-1300-00-0	Hose Connector Nut
4	1	B2-06-6000-07-0	31.6mm Hose Clamp
5	1	B2-02-7000-94-1	Nomex Breathing Hose
6	2	B3-04-0300-06-0	8": Cable Tie-Green
7	1	B2-02-7000-90-1	Nomex Inhalation Hose ID Label

ITEM#	QTY	PART NUMBER	DESCRIPTION
REF	-	B6-02-5000-76-1	Nomex Exhalation Hose Assembly
1	1	B2-02-7100-01-0	Hose Connector Gasket
2	1	B2-02-1300-01-0	Hose Connector Body
3	1	B2-02-1300-00-0	Hose Connector Nut
4	1	B2-06-6000-07-0	31.6mm Hose Clamp
5	1	B2-02-7000-94-1	Nomex Breathing Hose
6	2	B3-04-0300-05-0	8": Cable Tie-Red
7	1	B2-02-7000-91-1	Nomex Exhalation Hose ID Label

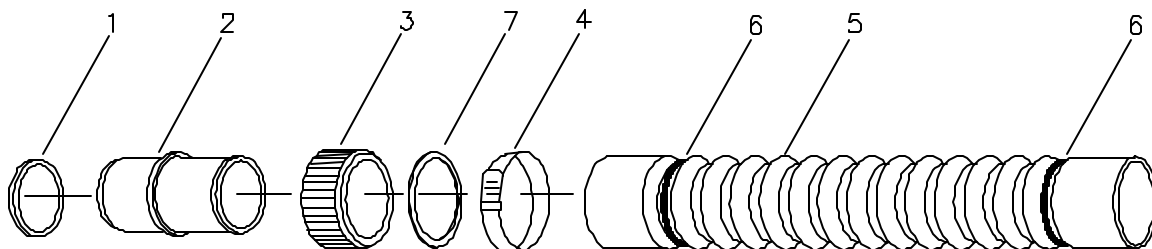

J. Breathing Chamber Cover Assembly

ITEM#	QTY	PART NUMBER	DESCRIPTION
REF	-		Biopak 60TE Breathing Chamber Cover Assembly
1	1	B6-02-5000-57-0	Formed Lid with Latches
2	1	B6-02-5000-11-0	Small Cooling Ring
3	1	B6-02-5000-10-0	Large Cooling Ring
4	4	B2-02-3300-20-0	Cooling Ring Mounting Bracket
5	1	B2-02-7000-11-0	Biopak 60TE Logo Label
6	4	B3-02-0070-00-0	#8-32 ESNA Hex Nut

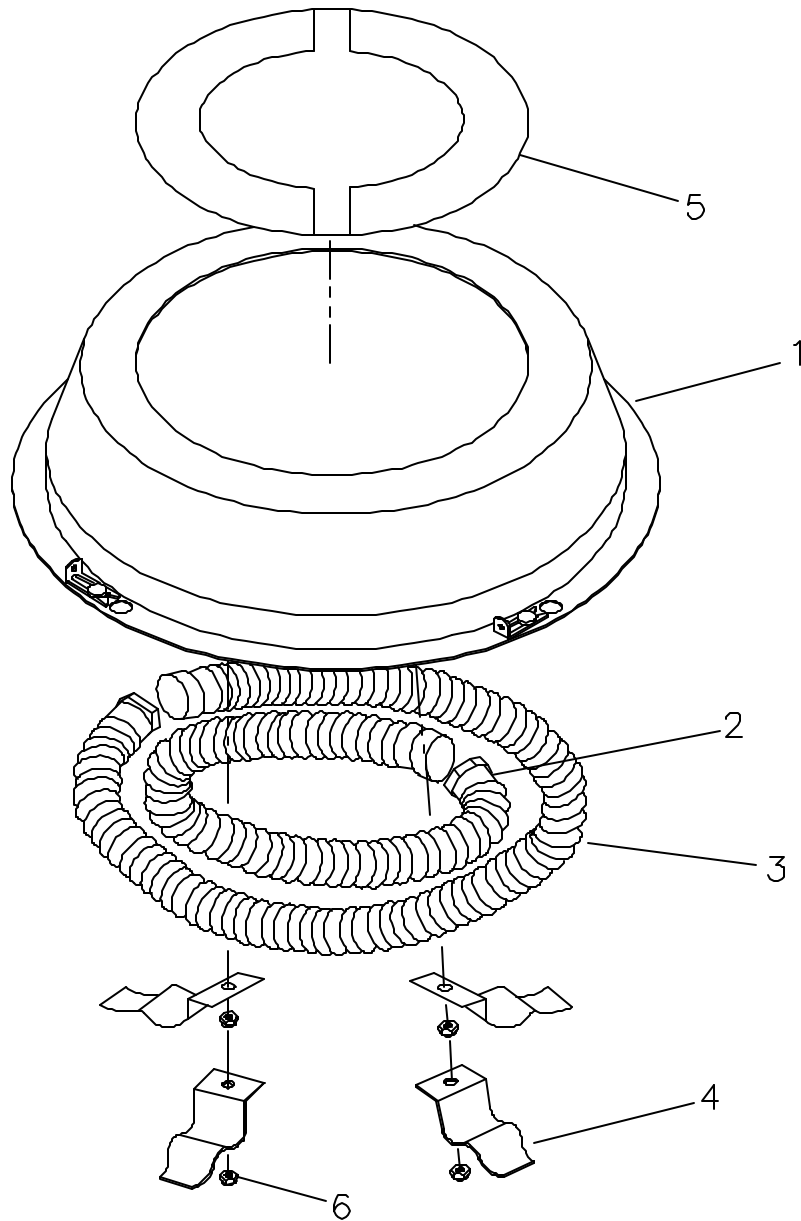

K. Oxygen Cylinder Assembly

ITEM#	QTY	PART NUMBER	DESCRIPTION
REF	-	B6-02-5000-12-0	Standard Oxygen Cylinder Assembly-FILLED
REF	-	B6-02-5000-12-1	Standard Oxygen Cylinder Assembly-EMPTY
REF	-	B6-02-5000-69-0	Japanese Oxygen Cylinder Assembly-FILLED
REF	-	B6-02-5000-69-1	Japanese oxygen Cylinder Assembly-EMPTY
1	1	B2-01-2000-01-0	Oxygen Cylinder
2A	1	B4-04-5500-01-0	Standard Cylinder Valve
2B	1	B4-04-5500-02-0	Japanese Cylinder Valve
3	1	B4-04-7060-00-0	O-Ring Seal, 1.012 OD x 0.734 ID
4A	1	B2-02-7000-13-0	Standard Cylinder Label
4B	1	B2-02-7000-38-0	Japanese Cylinder Label
5A	1	B2-05-1000-01-0	Standard Pressure Gauge
5B	1	B2-05-1000-01-1	Japanese Pressure Gauge

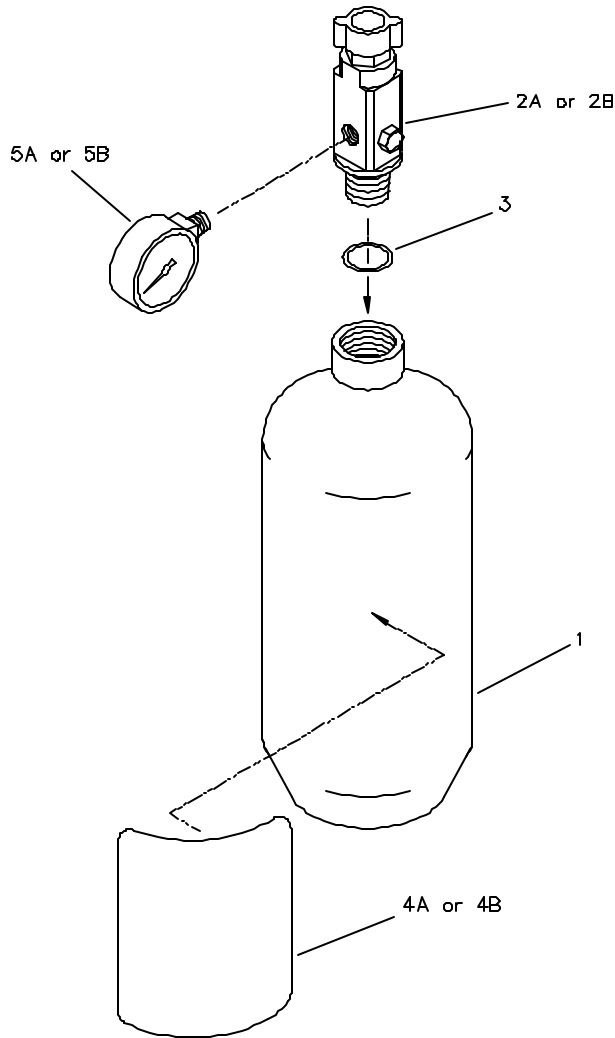

L. Scott-Style Facepiece Assembly

ITEM#	QTY	PART NUMBER	DESCRIPTION
REF ¹	1	B6-02-5001-45-0	Standard Facepiece Assembly-Small
REF ²	1	B6-02-5001-45-1	Standard Facepiece Assembly-Large
REF ³	1	B6-02-5001-45-2	Standard Facepiece Assembly-Extra Large
REF ¹	1	B6-02-5001-45-3	Wipered Facepiece Assembly-Small
REF ²	1	B6-02-5001-45-4	Wipered Facepiece Assembly-Large
REF ³	1	B6-02-5001-45-5	Wipered Facepiece Assembly-Extra Large
1 ¹	1	B2-06-6001-11-0	Facepiece with Lens-Small
2 ²	1	B2-06-6001-12-0	Facepiece with Lens-Large
3 ³	1	B2-06-6001-13-0	Facepiece with Lens-Extra Large
4	1	B6-02-5001-59-0	Adapter Assembly
5	2	B2-02-1300-04-0	Hose Adapter Fitting
6	1	B2-02-4100-17-0	Inhalation Check Valve Holder
7	1	B2-02-4100-16-0	Exhalation Check Valve Holder
8	2	B2-02-7100-06-0	Check Valve
9	2	B2-02-7100-07-0	Elbow Connector
10	2	B2-06-6000-24-0	38.1mm Hose Clamp
11	2	B2-06-6000-25-0	48.5mm Hose Clamp
12	1	B2-02-0000-30-0	Anti-Fog Lens Insert
13	1	B3-04-0300-05-0	Nylon 8" Red Cable Tie
14	1	B3-04-0300-06-0	Nylon 8" Green Cable Tie
15	2	B2-02-7000-12-0	Check Valve Holder Sealing Gasket
16	1	---	Wiper Assembly, Reference Page 57

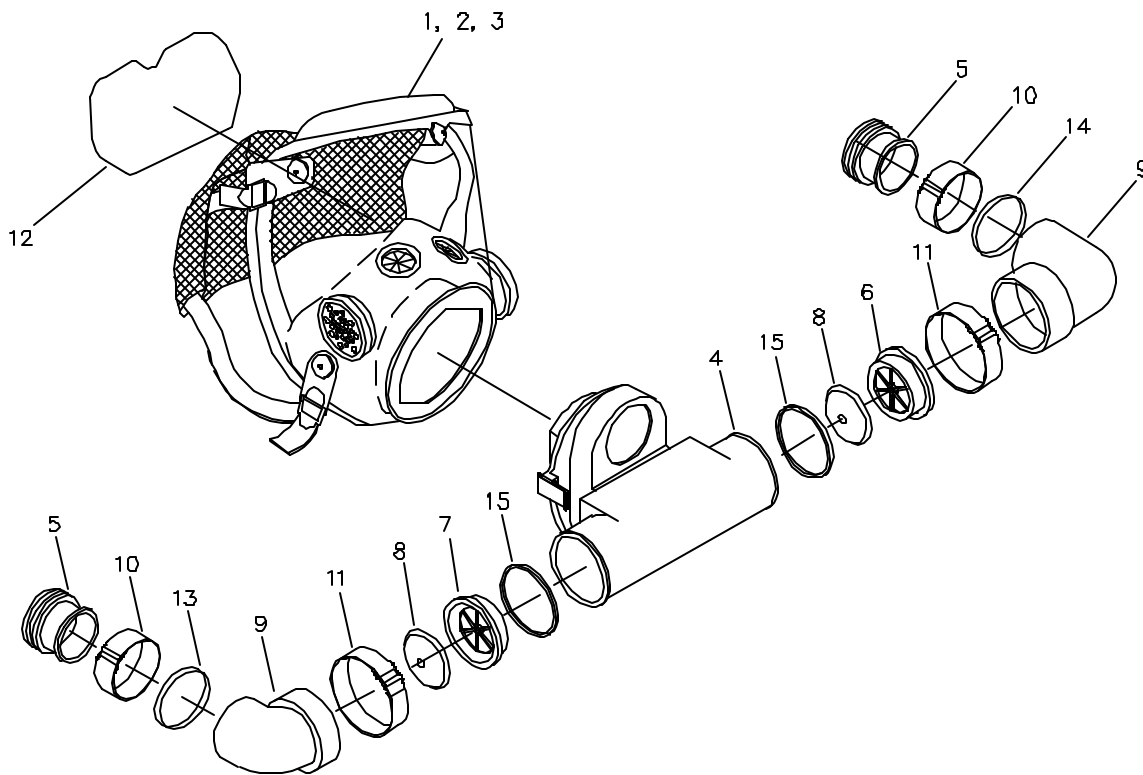

M. Scott-Style Facepiece Wiper Assembly

ITEM#	QTY	PART NUMBER	DESCRIPTION
REF	1	B6-02-5001-45-3	Wipered Facepiece-Small
REF	1	B6-02-5001-45-4	Wipered Facepiece-Large
REF	1	B6-02-5001-45-5	Wipered Facepiece-extra large
REF	-	---	Wiper Assembly Reference
1	2	B3-01-1022-00-0	#2-56 x 1/8" Binder Head Screw
2	2	B3-03-1023-00-0	#2 Flat Washer
3	1	B2-02-2400-04-0	Wiper Arm
4	1	B2-02-2400-05-0	Wiper Tension Arm
5	1	B6-02-5001-62-0	Replacement Wiper Blade Assembly
6	1	B2-02-3100-16-0	Wiper Feed Through
7	1	B4-04-7070-11-0	O-Ring Seal, .348 Outside Diameter
8	1	B6-02-5001-63-0	Wiper Through Bushing/Internal Washer Seal Washer
9	2	B2-02-7000-78-0	Wiper Seal Gasket
10	1	B2-02-3100-18-0	External Seal Washer
11	1	B2-02-3100-14-0	Jam Nut
12	1	B2-02-3100-12-0	Actuator Arm
13	1	B2-02-2400-03-0	Flex Arm
14	1	B2-02-3100-17-0	Wiper Arm Spacer
15	1	B3-01-1028-00-0	#2-56 x 3/8" Fillister Head Screw
16	1	B3-02-1020-00-0	#2-56 ESNA Hex Nut

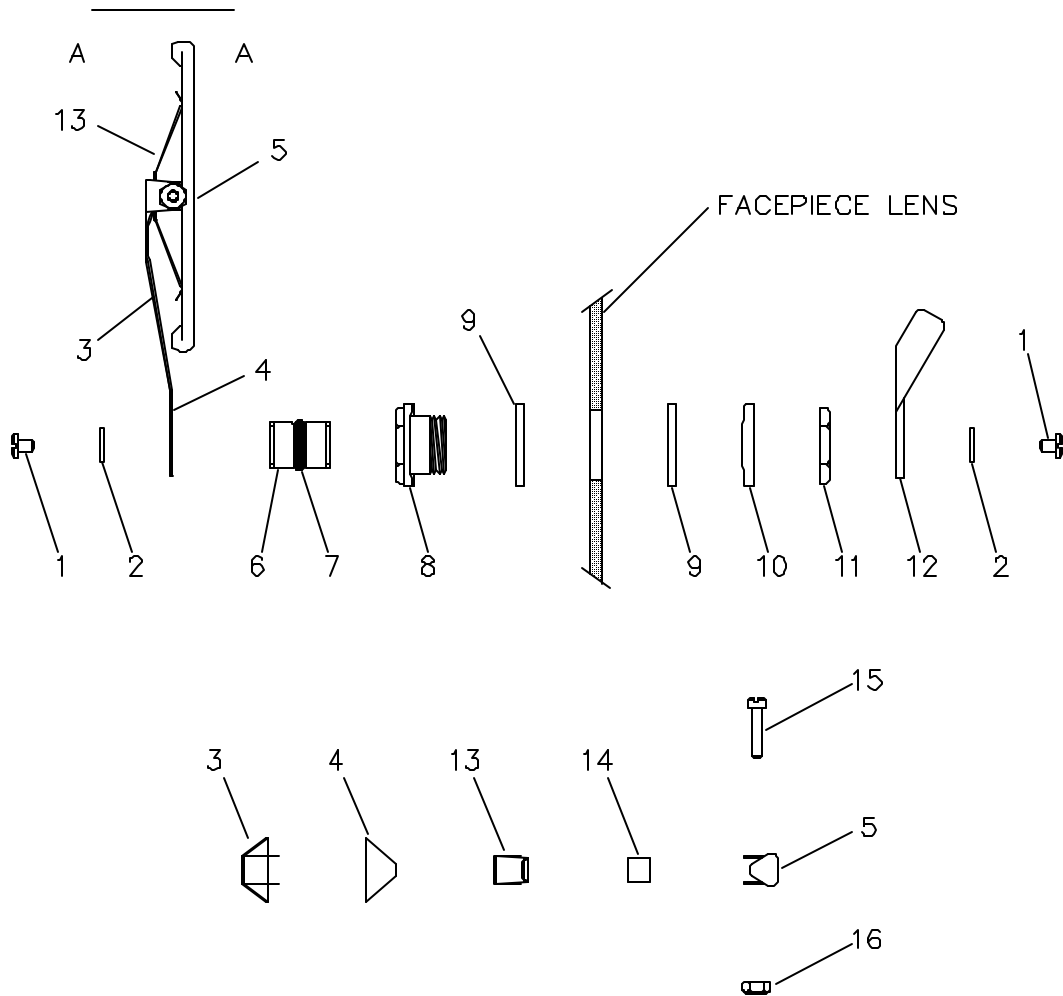

VIFW A-A

N. AGA-Style Facepiece Assembly

ITEM#	QTY	PART NUMBER	DESCRIPTION
REF	1	B6-02-5000-25-0	AGA-Style Facepiece with Speaking Diaphragm
REF	1	B6-02-5000-25-1	AGA-Style Facepiece with Voice Amplifier
REF	1	B6-02-5000-25-2	AGA-Style Facepiece with Wiper
REF	1	B6-02-5000-25-3	AGA-Style Facepiece with Microphone
1	1	B2-06-6000-45-0	AGA Facepiece
1a	1	B2-02-4400-00-0	Facepiece Lens
1b	1	B2-06-6000-59-0	Facepiece Frame with Screws
1c	1	B2-06-6000-58-0	Facepiece Head Strap
2	2	B2-02-7100-52-0	Condensation Pad
3	2ft	B2-06-6000-46-0	Ligarex Strap
4	1	B2-06-6000-44-0	Ligarex Lock
5	1	B6-02-5001-01-0	T-Bone Adapter Assembly
6	1	B4-04-7060-08-0	O-Ring Seal, 0.558" OD x 0.414" ID
7	1	B2-02-4100-31-0	Adapter Plug
8	1	B4-04-7070-05-0	O-Ring Seal, 1.943" OD x 1.737" ID
9	1	B2-02-3300-17-0	Speaking Diaphragm
10	2	B2-02-7000-12-0	Check Valve Holder Seal Gasket
11	2	B2-02-7100-06-0	Check Valve
12	1	B2-02-4100-17-0	Inhalation Check Valve Holder
13	1	B2-02-4100-16-0	Exhalation Check Valve Holder
14	2	B2-06-6000-25-0	48.5mm Hose Clamp
15	2	B2-02-7100-07-0	Elbow Connector
16	1	B3-04-0300-06-0	Nylon 8" Cable Tie-Green
17	1	B3-04-0300-05-0	Nylon 8" Cable Tie-Red
18	2	B2-06-6000-24-0	38.1mm Hose Clamp
19	2	B2-02-1300-04-0	Hose Adapter Fitting
20	1	B2-02-0000-30-0	Anti-Fog Lens Insert
21	1	B2-02-4100-32-0	Speaking Diaphragm Retainer
22	4	B3-01-1041-01-0	#4-40 x 3/8" Pan Head Screw
23	1	B2-02-1300-17-0	Voice Amplifier Adapter
24	1	B2-02-4000-00-0	Voice Amplifier Adapter Retainer
25	2	B3-01-1021-03-0	#2-56 x 1/4" Pan Head Screw
26	4	B3-01-1041-04-0	#4-40 x 5/8" Pan Head Screw
27	1	B1-15-3000-01-0	Voice Amplifier Module
28	1	B6-01-5000-00-0	Microphone Assembly
29	1	B2-02-1300-09-0	Microphone Flat Washer
30	1	B2-02-1300-09-0	Microphone Retaining Nut
31	1	B2-02-3100-09-0	Microphone Retainer

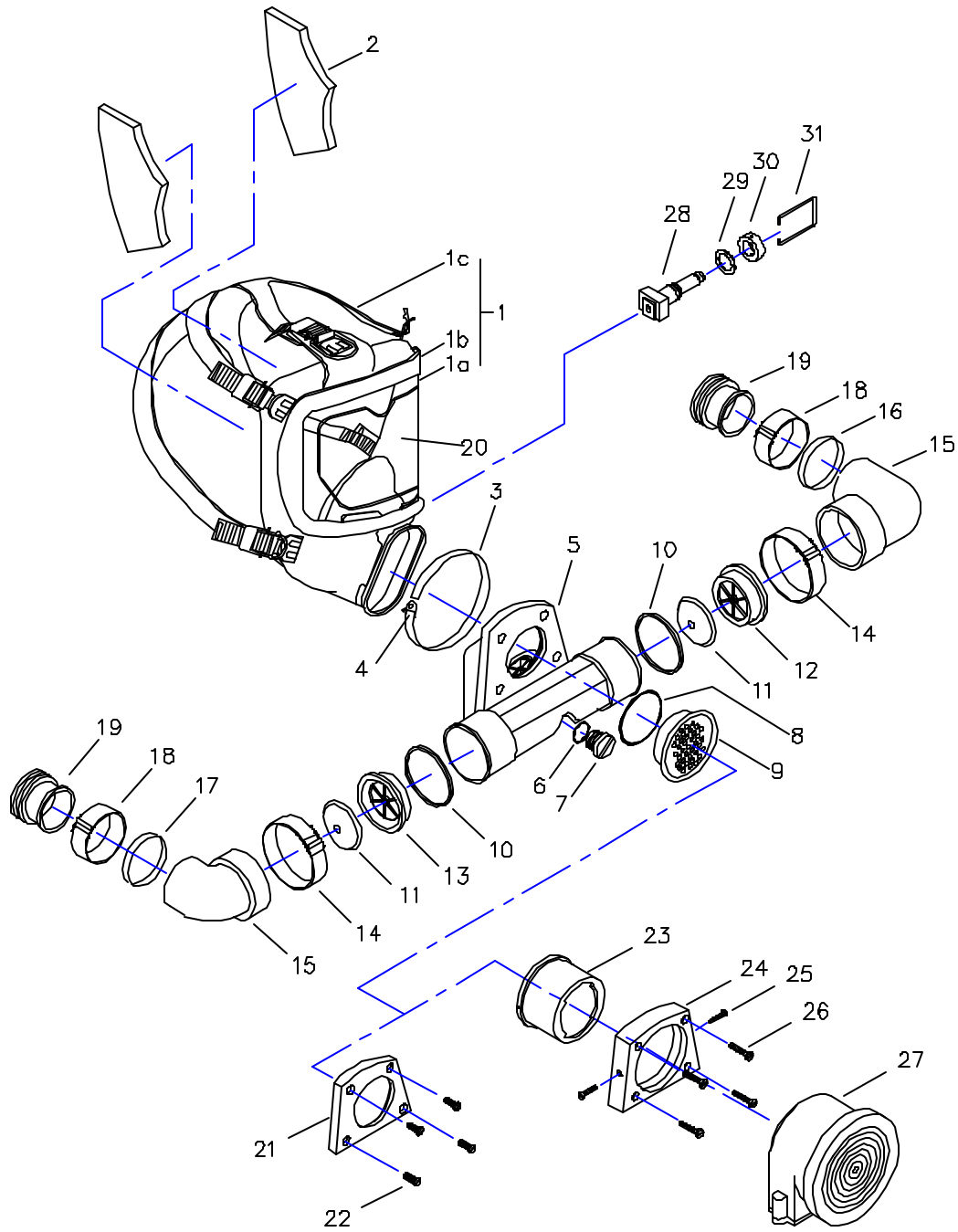

O. AGA-Style Facepiece Wiper Assembly

ITEM#	QTY	PART NUMBER	DESCRIPTION
REF	1	B6-02-5000-02-1	AGA -Style Facepiece Wiper Assembly
1	1	B2-02-4400-00-1	Modified AGA-Style Facepiece Lens
2	2	B3-05-3000-00-0	Spring Pin
3	2	B2-02-3100-04-0	Wiper Handle
4	2	B2-06-6000-38-0	3/8-32 Thin Hex Nut
5	4	B3-03-1133-00-0	Flat Washer
6	2	B3-04-0300-01-0	Sealing Grommet
7	2	B2-02-3100-05-0	3/8-32 Bushing
8	2	B4-04-7070-09-0	O-Ring Seal, 0.285" OD x 0.145" ID
9	2	B3-01-3061-00-0	#6-32 x 5/8" Self-Tapping Screw
10	2	B2-02-3100-06-0	Wiper Pivot Arm
*11	AR	---	Nylon Lacing Cord, 0.09" Wide x 0.012" Thick
12	1	B2-02-7100-13-0	Wiper Chamois
13	1	B2-02-3100-07-0	Flexible Cable

*Lacing cord is supplied with each replacement chamois, B2-02-7100-13-0.

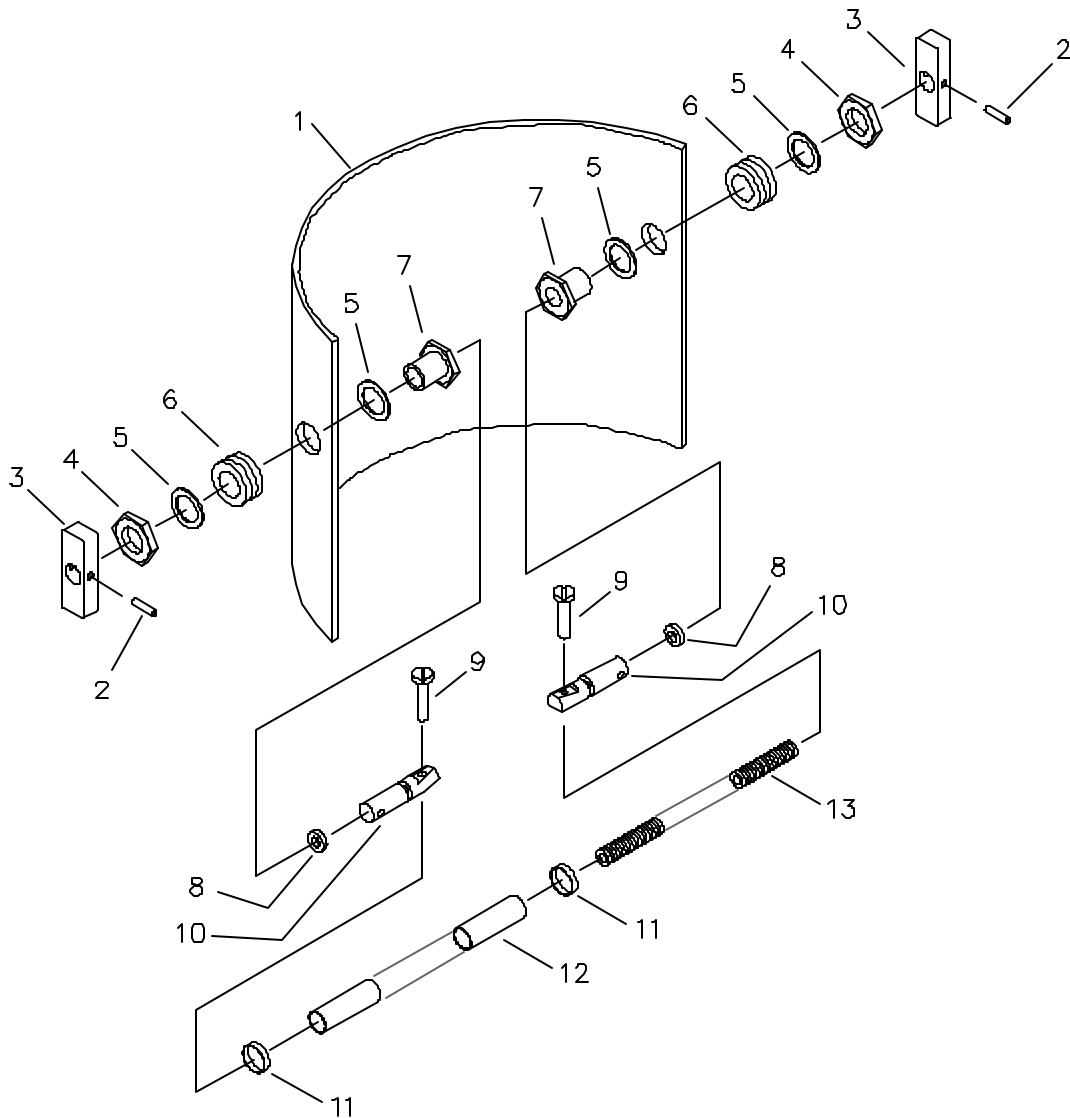

P. Service Kit Assembly

ITEM#	QTY	PART NUMBER	DESCRIPTION
REF	-	B6-02-5000-89-0	Biopak 60TE Service Kit Assembly
1	1	B6-02-5000-28-0	Biopak 60TE Spare Parts Kit
2	1	B6-02-5000-16-0	Flow Test Flowmeter
3	1	B6-02-5000-17-0	Test Key
*4	1	B6-02-5000-29-0	Leak Test Balloon Fixture
**5	4	B5-01-3000-02-0	Disinfectant Packet
6	1	B2-03-3000-02-0	Bypass Valve Wrench
7	1	B5-01-3000-01-0	Christo-Lube O-Ring Lubricant, 2-ounce tube
8	1	B5-01-3000-03-0	Leak-Tec leak Detection Fluid, 8-ounce bottle
9	1	B2-03-3000-03-0	Valve Core Tool
10	1	B2-03-3000-01-0	Vent Valve Wrench
11	1	B6-02-5000-08-0	Facepiece Ant-Fog Agent
12	1	B2-01-4100-01-0	Service Kit Case

* Replacement balloons for the leak test fixture can be ordered under part number B2-02-7000-17-0.

** B6-02-5000-42-0 will supply 75 packets of disinfectant.

Note: Dow -111 O-Ring Lubricant is not supplied with the Service Kit but may be ordered under part number B5-01-3000-11-0.

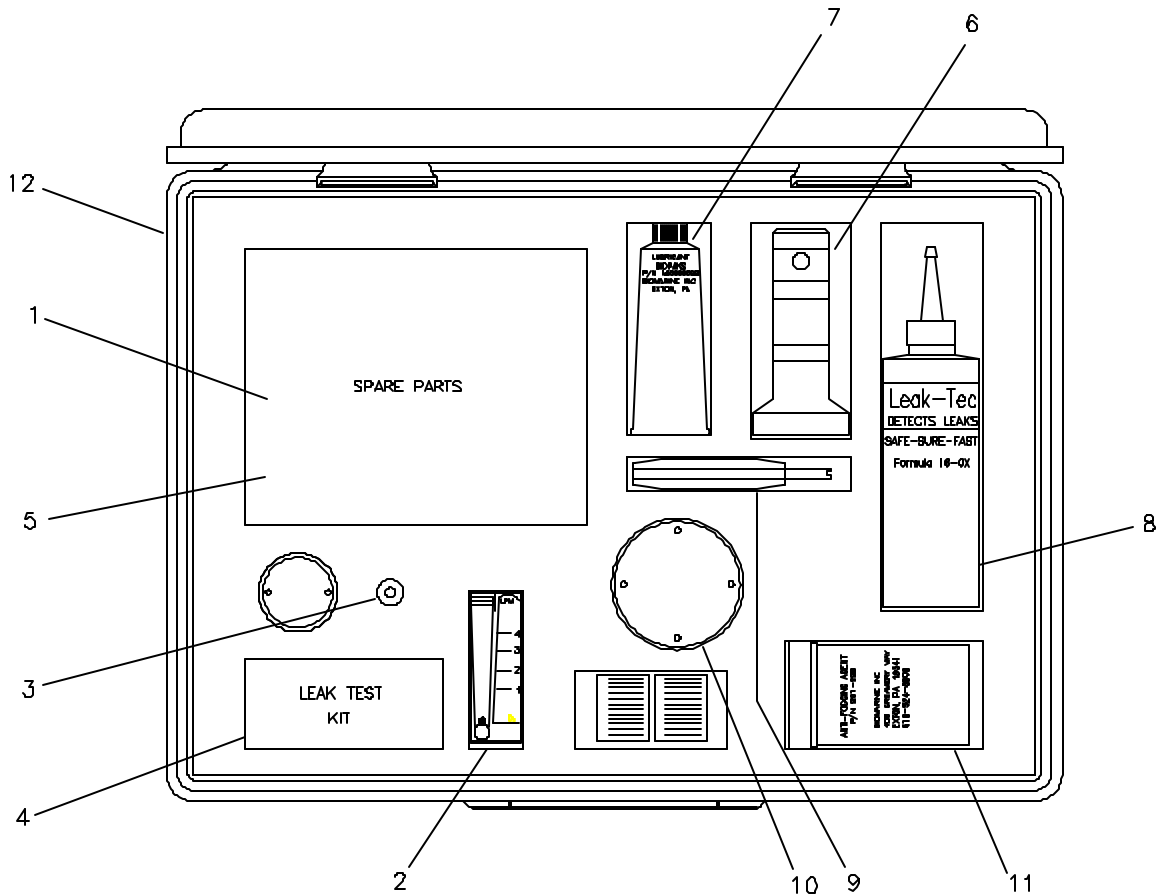

Appendix B: Material Hazards, Handling and First Aid

The following will provide the user with the potential hazards, the proper handling methods and recommended first aid for the carbon dioxide scrubbing media, Soda-Sorb and the facepiece anti-fog solution. Users are advised to consult the full Material Data Safety Sheet (MSDS) for each compound. Material Safety Data Sheets can be supplied, upon request, directly from Biomarine.

Soda-Sorb Carbon Dioxide Scrubbing Media

Commercial Name:	Soda-Sorb ^R 4-8 IND H MED
General Chemical Description:	Alkaline carbon dioxide absorbent
Hazards Identification:	Can cause irritation and present risk of serious damage to eyes. Can cause irritation to skin upon direct contact. Can cause irritation and injury to respiratory system if inhaled. Avoid skin and eye contact. Harmful if swallowed.
First Aid Measures:	Inhalation: Remove to fresh air. Obtain medical attention if discomfort persists. Skin: Drench with clean water. Obtain medical attention if irritation occurs and persists. Remove contaminated clothing. Eyes: Immediately irrigate thoroughly with clean water for at least 15-minutes. Obtain medical attention. Ingestion: Dilute with weak vinegar solution or a 5% solution of ammonium chloride if these are available. If not, dilute with large quantities of water. DO NOT INDUCE VOMITING. Obtain medical attention.
Handling & Storage:	Store in a clean dry environment. Avoid direct sunlight or temperatures below freezing. Keep containers closed.
Personal Protection:	Respiratory: Nuisance dust mask recommended. Skin: General purpose rubber gloves Eyes: Glasses to protect against dust. Hygiene: Wash after skin contact.

Facepiece Anti-Fog Solution

Commercial Name:	Horizon Anti-Fog Cloth
Chemical Name:	mixture
Hazards Identification:	Avoid contact with eyes. Dangerous by ingestion. May cause nausea, vomiting and diarrhea
First Aid Measures:	Inhalation: Not Irritating. Remove to fresh air. If breathing is difficult, have trained person administer oxygen. If respiration stops, administer artificial respiration. GET MEDICAL ATTENTION. Skin: Relatively brief exposure causes no known adverse effects. Flush thoroughly with cool water under shower while removing contaminated clothing and shoes. SEEK MEDICAL ATTENTION. Eyes: IMMEDIATELY FLUSH EYES WITH A DIRECTED STREAM OF WATER for at least 15 minutes, forcibly holding eyelids apart to ensure complete irrigation of all eye and lid tissue. GET MEDICAL ATTENTION IMMEDIATELY. Ingestion: NEVER GIVE ANYTHING BY MOUTH TO AN UNCONSCIOUS PERSON. If swallowed, have conscious person drink several glasses of water or milk. INDUCE VOMITTING. GET MEDICAL ATTENTION IMMEDIATELY.
Handling & Storage:	Store in container supplied by manufacturer.
Personal Protection:	Respiratory: No protection required when utilized as described in Biomarine Biopak manuals. Skin: Wear chemically protective gloves, boots, aprons, and gauntlets to prevent prolonged or repeated skin contact during application to Biopak facepiece. No protection required during normal Biopak use. Eyes: Wear protective eyeglasses or chemical safety goggles, per OSHA eye- and face-protection regulations (29 CFR 1910.133) during application to Biopak facepiece. No protection is required during normal Biopak use. Hygiene: Practice good personal hygiene after using this material, especially before eating, drinking, smoking, using the toilet, or applying cosmetics.