

LIQUID TRAP

PRODUCT DATA SHEET-107

Continuous coarse liquid removal and drainage—for use with Neutronics Process Gas Sampling Systems

FEATURES

- Continuously removes accumulated liquids and droplets from sample stream
- Minimizes Sample Stream Pressure Drop
- Maintenance-free

DESCRIPTION

The Liquid Trap is a pre-conditioning component used in addition to a standard Sample Conditioning Package to assure analyzer reliability. The Liquid Trap removes liquids and droplets from the sample line. Sample gas enters the input at the top and makes a sharp 180° “u-turn” in the body of the Liquid Trap. Liquid droplets do not make the turn and continue in to the drain line. Dry sample gas exits from the outlet. The Liquid Trap can be used in positive pressure and vacuum installations.

POSITIVE PRESSURE INSTALLATIONS

With a positive pressure on the input port, ambient air will not contaminate the sample stream through the drain port. However, a restrictor valve is required on the drain line to provide backpressure to the sampler. Waste liquid is plumbed from the drain port to any appropriate drain.

VACUUM INSTALLATIONS

With a vacuum potential on the outlet port, a Negative Pressure Auto-Drain (ref. PDS-102) must be used on the drain port to provide maintenance-free, and continuous drainage, without allowing ambient air to contaminate the sample stream.

INSTALLATION

The Liquid Trap must be vertically mounted in the sample line between the sampled process and the Sample Conditioning Package. The sample input line must be a minimum 3/8” tube or pipe, and the output line a minimum 1/4”.

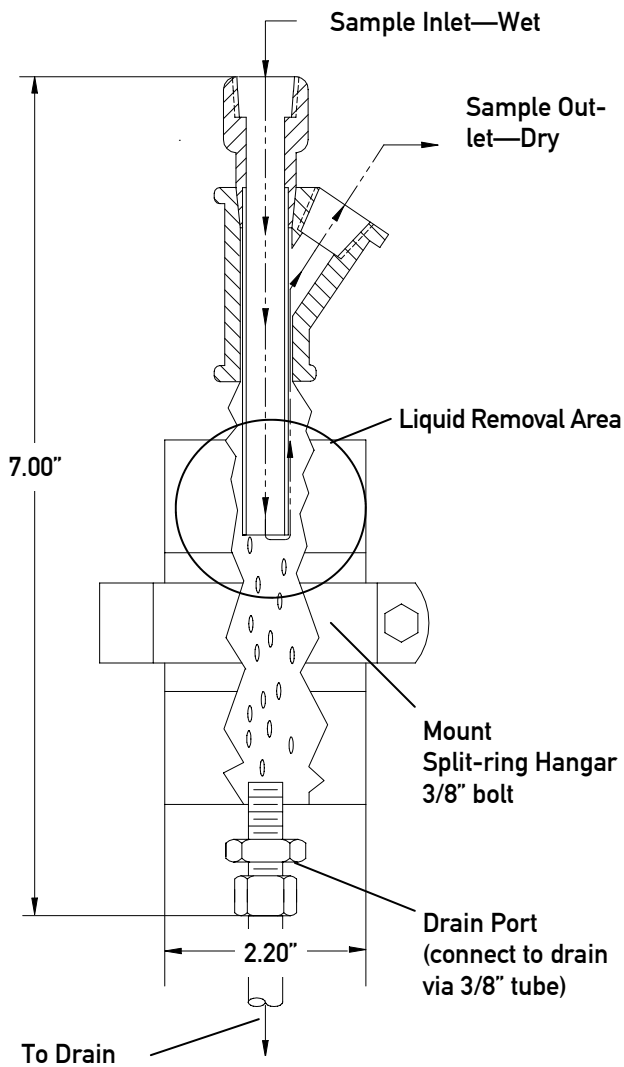

SPECIFICATIONS

MATERIALS	Available in Brass/copper, Stainless Steel, Hastelloy, or Kynar/Teflon
REFERENCE DRAWING	SP-C-0437
INLET/OUTLET	1/2" FNPT/1/2" FNPT
DRAIN PORT	3/8" Tube Compression Fitting



Mullaghboy Industrial Park, Navan, Co Meath, Ireland
Phone: 00353 469071333 Fax: 00353 469071331 Email: info@ntron.com
www.ntron.com

REV 0 — May 9, 2003