

# NTRON SAMPLER TECHNOLOGY

PROCESS OXYGEN SAMPLE CONDITIONING PACKAGE WITH TRANSMITTER SENSORS AND AUTO CALIBRATION VALVE



ALL-TEFLON HEATED OXYGEN SAMPLE CONDITIONING PACKAGE FOR HIGHLY CORROSIVE APPLICATIONS



STREAMLINED OXYGEN SAMPLER WITH INTEGRATED TRANSMITTER FOR DRY POWDER/OEM APPLICATIONS

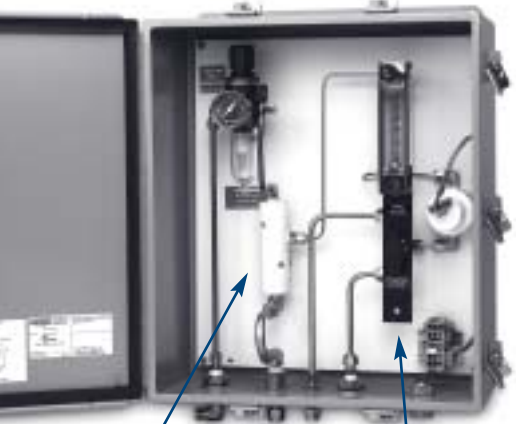

VENTURI PUMP



SAMPLE / CALIBRATION GAS SELECTOR

## PROCESS OXYGEN GAS ANALYSIS APPLICATION WORKSHEET

DATE: \_\_\_\_\_

Please fill out this worksheet to allow us to specify the proper sample conditioning components for your process gas monitoring and control application. Ntron respects the confidentiality of all information provided to us on this worksheet.

### CONTACT INFORMATION:

Name: \_\_\_\_\_  
 Title: \_\_\_\_\_  
 Company: \_\_\_\_\_  
 Address: \_\_\_\_\_  
 City: \_\_\_\_\_ Country: \_\_\_\_\_  
 Phone: \_\_\_\_\_  
 Fax: \_\_\_\_\_  
 Email: \_\_\_\_\_

### UTILITIES: (check availability)

Power: 115 VAC 230 VAC Other: \_\_\_\_\_  
 Instrument Air: Yes No  
 Pressure: \_\_\_\_\_ PISG  
 Inert Gas: Yes No  
 Pressure: \_\_\_\_\_ PISG  
 Type: N2 CO2 Other: \_\_\_\_\_  
 Cooling Water Temperature: \_\_\_\_\_ °C or °F

### APPLICATION:

Describe Process:  
 \_\_\_\_\_  
 \_\_\_\_\_  
 \_\_\_\_\_  
 \_\_\_\_\_

### PROCESS CHEMICAL COMPOSITION: (list everything)

SOLVENT	% VOLUME
_____	_____
_____	_____
_____	_____
_____	_____

### GAS TO MONITOR:

Oxygen- Range: \_\_\_\_\_ % ppm  
Flammable- Specific Gas(es): \_\_\_\_\_  
 Range: \_\_\_\_\_ LEL VOL  
Toxic Gas(es): \_\_\_\_\_  
Other- Specific Gas(es): \_\_\_\_\_  
 Range: \_\_\_\_\_

### PARTICULATES: (types & sizes)

\_\_\_\_\_  
 \_\_\_\_\_

### SPECIAL CONSIDERATIONS:

\_\_\_\_\_  
 \_\_\_\_\_

### VESSEL:

Vessel Type: \_\_\_\_\_  
 Vessel Materials of Construction: \_\_\_\_\_  
 \_\_\_\_\_  
 Vessel Volume: \_\_\_\_\_  
 Vessel Usage: \_\_\_\_\_  
 \_\_\_\_\_  
 Vessel Location: Indoor Outdoor (check one)  
 Area Rating at Vessel Site: \_\_\_\_\_

### MATERIALS THAT WITHSTAND CONTACT WITH SAMPLE:

\_\_\_\_\_  
 \_\_\_\_\_

### DIAGRAM PROCESS:

Please provide diagram of process here and attach additional pages if necessary.

### PROCESS VESSEL VACUUM/PRESSURE RANGE:

Please indicate with proper units.  
 Min: \_\_\_\_\_ Normal: \_\_\_\_\_ Max: \_\_\_\_\_

### TEMPERATURE: (please specify °C or °F)

Vessel Temperature:  
 Min: \_\_\_\_\_ Normal: \_\_\_\_\_ Max: \_\_\_\_\_  
 Ambient Temperature:  
 Min: \_\_\_\_\_ Normal: \_\_\_\_\_ Max: \_\_\_\_\_

FAX TO 00353 46 9071331

ML125, Rev. B



Mullaghboy Industrial Park, Navan, County Meath, Ireland.  
 Phone: 353 46 9071333 • Fax: 353 46 9071331 • Email: info@ntron.com  
 www.ntron.com



# PROCESS GAS SAMPLING SYSTEMS

ENGINEERED SOLUTIONS FOR PROCESS CONTROL RELIABILITY

BUILT-TO-ORDER  
 CUSTOM DESIGNS AVAILABLE  
 INTRINSICALLY SAFE  
 CORROSION RESISTANT NEMA 4X  
 USABLE WITH ANY NEUTRONICS PROCESS GAS ANALYZER/CONTROLLER

PNEUMATICALLY POWERED  
 VAPOR CONDITIONING  
 FLOW-LOSS INDICATOR

## WHAT IS SAMPLE CONDITIONING?

For accurate and reliable measurement of industrial processes gases, sensors must have stable, and clean sample gas streams delivered to them. Aggressive conditions experienced in many industrial processes make it important to prepare sampled gases before measurement, to protect sensors.

Ntron Sample Conditioning Systems effectively remove any damaging contaminants from dirty, humid, and corrosive process gas samples before they reach our sensors, helping to make our process control systems the most dependable.

## THE NTRON ADVANTAGE

Sampling gas from a process vessel or stream for process-control can pose serious challenges to Engineers. Here's where Ntron can help. Our experience and hands-on approach to each new application ensures that you receive the most effective and reliable system for your unique needs, every time.

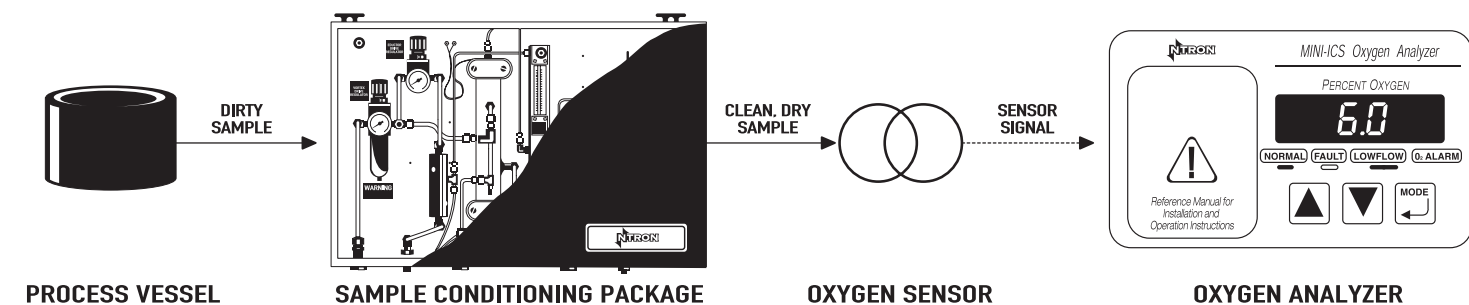

# SAMPLE CONDITIONING

ENGINEERED SOLUTIONS.

*When you work with a Ntron Application Engineer, you have at your disposal 25+ years of our collective experience in the design of custom industrial process instrumentation and control systems.*

No matter what sensor technology you choose, monitoring an industrial process stream presents challenges to system reliability and longevity.

Manufacturing processes that involve corrosive chemicals, temperature extremes, heavy dust-clouds, and other aggressive conditions must be evaluated individually for control system reliability and longevity. The Ntron Sample Conditioning packages are designed and specified case-by-case, to suit your process, making sure our sensors always have clean, dry sample gas for accurate measurement.

Ntron' decades of experience in process gas Sampling began with the integration of an Oxygen-based Inert Gas Control system for one of the world's largest chemical manufacturers (please

ask a Ntron representative about our world-class process control systems). In protecting that company's people and facilities (and many others) for over two decades we have developed a rule of hands-on customer-intimacy.

By listening and responding to our valued users, Ntron has become the leader in engineering process control systems involving gas analysis. We are pioneers in process gas sample conditioning, having designed and installed tens-of-thousands of systems in all types of manufacturing plants.

We pride ourselves on our experience, and we stand behind our designs with a guarantee that our system will work reliably on your application. We understand

that the key to gas analyzer accuracy and reliability is a sample free of contaminants that can destroy sensors, and the way to provide that is with an application-driven sample conditioning system, engineered by people with hands-on experience and expertise.

*"Ntron' Engineers are pioneers of Process gas sample conditioning."*

Whatever challenges you face, we have ready-solutions, developed over years of experience, and driven by the needs of Process Engineers just like you. We also understand that your technical AND commercial needs require our absolute attention and that we must deliver the right system at the right time, and at the right cost.

## COMPONENTS:

## HOW SAMPLE CONDITIONING WORKS...

How do we achieve what we do? Here again, we give you the benefit of our experience by making available a wide variety of Ntron-developed, standardized components, provided in SPECIFIED-TO-ORDER configurations to solve your individual process gas monitoring and control needs:

To provide the sensor with a continuous sample, Ntron has complete sample extraction capabilities. We have provided oxygen analysis systems for use in continuous or varying pressure, from a complete vacuum, to 15 BAR G.

Continuous Positive Pressure within the vessel can provide the motive force to push the sample through the sampling package to the sensor.

A pneumatically driven Ntron Aspirator is an ideal means of drawing a sample in many applications. It is intrinsically safe and has no moving parts.

When compressed gas is not available, or process vacuum is high, a Vacuum Pump is used to draw a sample from the vessel. Sized to the application, the vacuum pump is also used when aspirator compressed gas consumption is of concern.

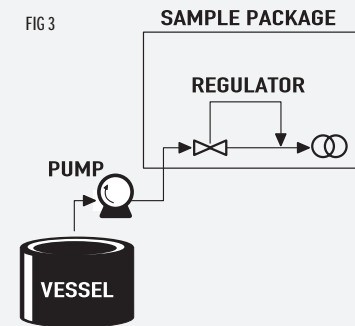
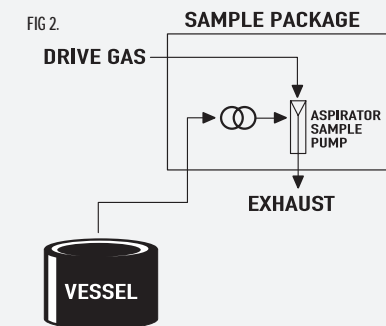
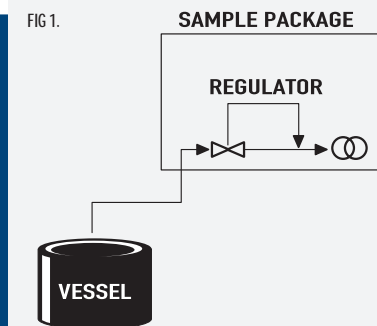

### VAPOR, MIST & CONDENSATION

Only Ntron offers a standard line of components that prevent process vapor, mist and condensed liquid from deteriorating oxygen sensor accuracy and reliability.

When the sample is equal to, or slightly above ambient temperature, our Vapor Condenser may be used to remove Light Vapor & Condensate (ref. TDS-109).

For elevated sample temperatures with entrained liquid droplets or mist, an Ntron Liquid Trap (ref. TDS-107) or Coalescing Pre-Filter (ref. TDS-101) may be used in addition to the Vapor Condenser to remove Moderate vapor, mist and Entrained Liquids.

Our Negative Pressure Autodrain continuously drains collected liquids, while preventing ambient air from entering the sample line on vacuum applications. (ref. TDS-102).

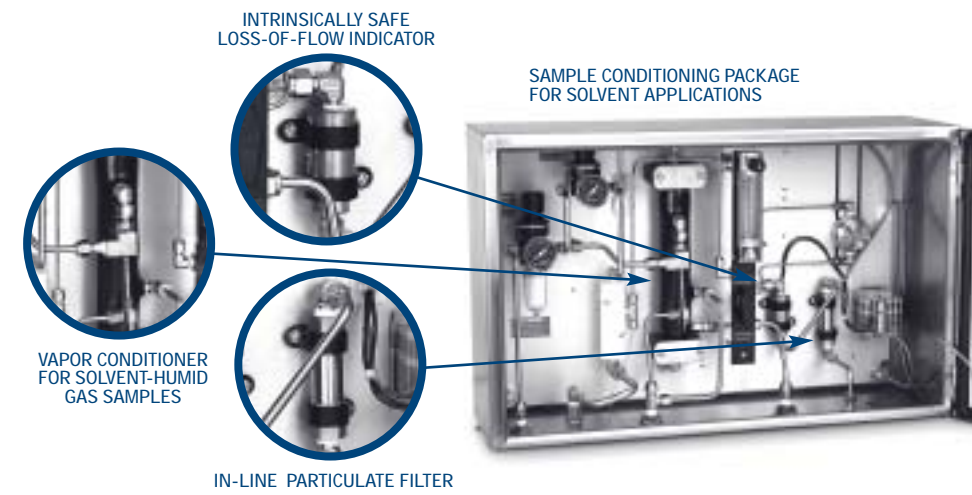

*Ntron Sampling systems are designed and built to last in the most aggressive industrial manufacturing environments. Our Sample Conditioning Packages are proven to minimize maintenance and down-time. Thousands of these award-winning systems are installed worldwide, protecting the plant the worker and the environment.*

### PARTICULATE REMOVAL

For dusty applications, we have a complete selection of filters. Proper filter sizing requires a complete knowledge of the size and quantity of process particulates.

A standard in-line sample filter is in all our packages to remove Light Particulates.

An external pre-filter may be required for Moderate Particulate Loads that could overload the internal filter (ref. TDS-101).

The Ntron Blow Back Filter is a self-cleansing filter for Heavy Particulate Loads (ref. TDS-105).

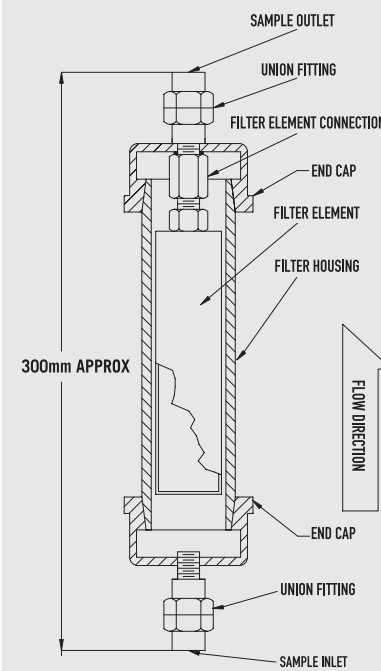

### CHEMICAL REMOVAL

We provide many "off-the-shelf" solutions to chemicals that could affect proper sensor performance.

Our Spray Scrubber continuously scrubs the sample stream of harmful chemicals or particulates with water (ref. TDS-104).

The Ntron Bubble Scrubber washes contaminants from the sample flow with a replenishable liquid for trace applications or when continuous scrubbing is unavailable (ref. TDS-106).

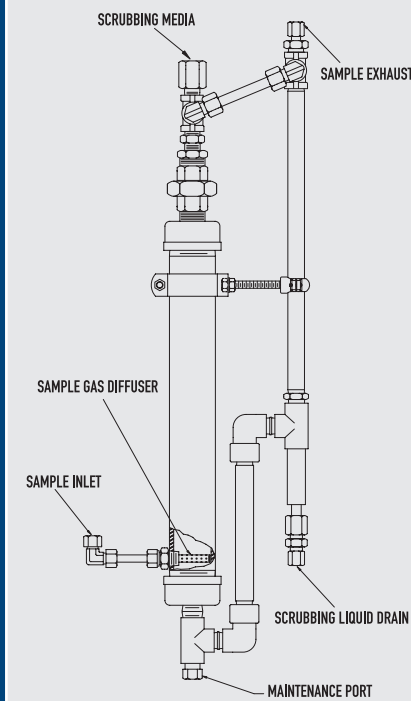

### SAMPLE TEMP

High Sample Gas Temperatures may require a cooling coil of thin-walled tubing or water-cooled heat exchangers. The Ntron Water Cooled Demister provides cooling along with heavy vapor and mist removal (ref. TDS-103).

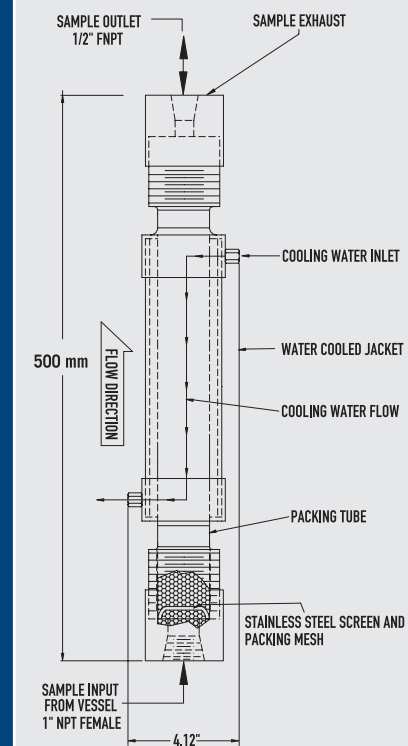

### AMBIENT TEMP

Where sample packages are mounted in outdoor areas, and subject to high or low temperature extremes, Ntron Inc. has available a variety of sample package heating and cooling options.

All climate control options include thermostats, cabinet insulation and can be provided suitable for hazardous area mounting.

### SYSTEM

#### MATERIALS OF CONSTRUCTION

Your process determines wetted system component materials.

Standard Solvent Resistant components of brass, Teflon (all wetted seats, seals and tubing), nylon, delrin, and aluminum are used when the sample does not contain corrosives.

Chemical Resistant components of stainless steel, glass, Teflon, kynar and kalrez provide resistance to most chemicals and solvents.

### ENCLOSURES

Expensive explosion-proof enclosures are never needed, all Ntron Sample Conditioning Components are pneumatically driven and intrinsically safe. Enclosure choice is determined by the area in which the Sampling Package will be located.

#### INDOOR/OUTDOOR USE

IP65 Stainless Steel Enclosure.

### HERE'S WHAT TO DO WHENEVER YOU NEED TO MONITOR PROCESS GAS:

Call an Ntron division Field Engineer at (353) 46 9071333, or simply fill out the attached Application worksheet and Fax it to (353) 46 9071331. The information that you provide will allow us to configure a complete system for your need. Remember, our systems are custom configured, and guaranteed for your application.

Ntron sampling systems are designed to work with all of our quality gas monitoring and control systems. For complete information on our capabilities, please ask any Ntron representative, or visit us online at [www.ntron.com](http://www.ntron.com).